

# Table of Contents

## FWF-BT/BF

4-Way blow ceiling mounted cassette .....	<b>1</b>	FWF-BT	..... 39
4-Way blow ceiling mounted cassette .....	<b>2</b>	FWF-BF	..... 55



# TABLE OF CONTENTS

## FWF-BT

1	Features .....	40
2	Specifications .....	41
	Technical Specifications .....	41
	Electrical Specifications .....	41
3	Electrical data .....	42
	Electrical Data .....	42
4	Safety device settings .....	43
	Safety Device Settings .....	43
5	Options .....	44
	Options .....	44
6	Capacity tables .....	46
	Cooling Capacity Tables .....	46
	Heating Capacity Tables .....	47
7	Dimensional drawings .....	48
	Dimensional Drawings .....	48
	Dimensional Drawings with Accessories .....	49
8	Centre of gravity .....	50
	Centre of Gravity .....	50
9	Piping diagrams .....	51
	Piping Diagrams .....	51
10	Sound data .....	52
	Sound Power Spectrum .....	52
	Sound Pressure Spectrum .....	53
11	Hydraulic performance .....	54
	Water Pressure Drop Curve Evaporator .....	54

# 1 Features

- Modern style decoration panel in white (RAL9010)
- Compact casing (570mm in width and depth) enables unit to fit flush into ceilings and match standard architectural modules, without cutting ceiling tiles
- Comfortable horizontal auto swing ensures draughtfree operation and prevents ceiling soiling
- Fresh air intake for healthy living
- Possibility to shut 1 or 2 flaps for easy installation in corners
- Standard drain pump with 750mm lift



2

1

## 2 Specifications

2-1 Technical Specifications				FWF02BT	FWF03BT	FWF04BT	FWF05BT
Cooling capacity	Total capacity	Super high	kW	2.0 (1)	3.2 (1)	4.2 (1)	5.2 (1)
		High	kW	1.7 (1)	2.8 (1)	3.3 (1)	4.0 (1)
		Low	kW	1.5 (1)	2.5 (1)		2.9 (1)
	Sensible capacity	Super high	kW	1.5 (1)	2.0 (1)	2.8 (1)	3.5 (1)
		High	kW	1.3 (1)	1.7 (1)	2.1 (1)	2.7 (1)
		Low	kW	1.1 (1)	1.4 (1)		1.8 (1)
Heating capacity	2-Pipe	Super high	kW	2.9 (2)	4.0 (2)	5.4 (2)	6.7 (2)
		High	kW	2.6 (2)	3.4 (2)	4.1 (2)	5.3 (2)
		Low	kW	2.3 (2)	2.8 (2)		3.6 (2)
Power input	Super high	W	74		90	118	
	High	W	67		70	89	
	Low	W	60		55	62	
Casing	Material		Galvanised steel plate				
Dimensions	Unit	Height	mm	285			
		Width	mm	575			
		Depth	mm	575			
Weight	Unit	kg	19				
Heat exchanger	Rows	Quantity	2				
	Fin pitch		mm	1.5			
Water pressure drop	Cooling	kPa	6	19	31	42	
	Heating	kPa	6	19	31	42	
Fan	Type		Turbo fan				
	Quantity		1				
	Air flow rate	High	m <sup>3</sup> /h	468	660	876	
		Medium	m <sup>3</sup> /h	390	486	648	
Low		m <sup>3</sup> /h	318		420		
Fan motor	Speed	Steps	3				
	Model		QTS32C15M				
Sound power level	Super high	dBA	44	50	55		
	High	dBA	40	44	49		
	Low	dBA	36		42		
Sound pressure level	Super high	dBA	31	40	45		
	High	dBA	27	33	39		
	Low	dBA	26		30		
Insulation material			Foamed polystyrene / foamed polyethylene				

Standard Accessories : Screws;

Standard Accessories : O ring;

Standard Accessories : Insulation;

Standard Accessories : Washer for hanger bracket;

Standard Accessories : Clamp for drain hose;

Standard Accessories : Installation and operation manual;

Standard Accessories : Installation guide;

Standard Accessories : Drain hose;

2-2 Electrical Specifications			FWF02BT	FWF03BT	FWF04BT	FWF05BT
Power supply	Phase		1~			
	Frequency	Hz	50			
	Voltage	V	220-440			

### Notes

(1) Cooling: air 27°CDB, 19°CWB; entering water 7°C; leaving water 12°C

(2) Heating: 2 pipe: air 20°CDB; entering water 50°C

(3) Do not let water of less than 5°C or more than 50°/70°C enter the unit, this may damage the unit

(4) Height includes switch box

### 3 Electrical data

#### 3 - 1 Electrical Data

**FWF-BT-BF**

UNITS					POWER SUPPLY		IFM		INPUT (W)	
MODEL	TYPE	Hz	VOLTAGE RANGE	VOLTAGE LIMITS	MCA	MFA	kW	FLA	COOLING	HEATING
FWF02BT	V1	50	220-240	MAX. 264 MIN. 198	0.6	16	0.055	0.5	74	74
FWF03BT					0.6	16	0.055	0.5	74	74
FWF04BT					0.7	16	0.055	0.6	90	90
FWF05BT					0.8	16	0.055	0.7	118	118
FWF02BF	V1	50	220-240	MAX. 242 MIN. 198	0.6	16	0.055	0.5	74	74
FWF03BF					0.6	16	0.055	0.5	74	74
FWF04BF					0.7	16	0.055	0.6	94	94
FWF05BF					0.8	16	0.055	0.7	121	121

Symbols:

- MCA: Min Circuit Amps (A)
- MFA: Max. Fuse Amps (See note 5)
- kW: FAN Motor Rated Output (kW)
- FLA: Full Load Amps (A)
- IFM: Indoor Fan Motor

**NOTES**

1. Voltage limits:  
Units are suitable for use on electrical systems where voltage supplied to unit terminals is not below or above listed range limits.
2. Maximum allowable voltage unbalanced between phases is 2%.
3. MCA/MFA  
MCA = 1.25 x FLA  
MFA <= 4 x FLA  
(Next lower standard fuse rating min. 16A)
4. Select wire size based on the MCA.
5. Instead of fuse, use Circuit Breaker.

4TW33041-2

2  
3

## 4 Safety device settings

### 4 - 1 Safety Device Settings

FWF-BT-BF

		02	03	04	05
FWF-BF/BT	PC board fuse	250V 5A			
	Fan motor thermal fuse	°C	---		
	Fan motor thermal protector	°C	OFF: 130±5 ON: 83±20		

4TW33049-4

# 5 Options

## 5 - 1 Options

2  
5

### FWF-BT/BF

#### Options

Item	Model	FWF02-05B
1	Decoration Panel (RAL 9010 - grey sealings)	4-way blow BYFQ60B
2	Sealing member of air discharge outlet	KDBH44BA60
3	Panel spacer	KDBQ44B60
4	Long-life filter	KAFQ441BA60
5	Fresh air intake kit	Direct installation type KDDQ44XA60

#### Control system

Item	Model	FWF02-05B	
1	Remote control	Infrared	
		H/P	BRC7E530 (*12)
		C/O	BRC7E531 (*12)
	Wired	BRC315D7 (*1)	
2	Central remote control	DCS302CA51 (*2)	
2.1	Electrical box with earth terminal (3 blocks)	KJB311A	
3	Unified on/off controller	DCS301BA51 (*5)	
3.1	Electrical box with earth terminal (2 blocks)	KJB212A	
4	Schedule timer	DST301BA51 (*5)(*8)	
5	Wiring adapter for electrical appendices (1)	KRP2A52 (*4)(*8)	
6	Wiring adapter for electrical appendices (2)	KRP4AA53 (*4)(*8)	
7	Installation box for adapter PCB	KRP1BA101 (*9)	
8	Remote sensor	KRCS01-1	
10	Intelligent touch controller	DCS601C51C (*3)(*7)	
10.1	Electrical installation box	KJB411A	
11	Optional PCB for MOD-bus connection	EKFCMBCB7 (*4)(*8)	
12	2-way valve - On/Off	EKMV2C09B7 (*4)(*6)(*10)	
13	3-way valve - On/Off	EKMV3C09B7 (*4)(*6)(*10)	
14	Valve control PCB	EKRPTC11	
15	Remote "On/Off" and "forced off" kit	EKROROA (*11)	

#### NOTES

- \*1. Optional, electrical installation box with earth terminal KJB212A is required, if controller wires need to be installed in the wall.
- \*2. Requires electrical installation box with earth terminal KJB311A.
- \*3. Requires electrical installation box KJB411A.
- \*4. Requires installation box KRP1BA101.
- \*5. Requires electrical installation box with earth terminal KJB212A if built in the wall.
- \*6. Requires valve control PCB EKRPTC11.
- \*7. I-touch:
  - Not allowed to use the i-touch for an installation with both fan coils and VRV® units.
  - Can not be used in combination with fan coil units, that use MOD bus communication.
  - No Airnet or telephone connection possible.
- \*8. Only 1 of these 4 options can be installed on 1 indoor unit.
- \*9. Max. 2 KRP1BA101 boxes can be mounted on the unit. Max. 1 PCB can be mounted in 1 KRP1BA101 box.
- \*10. 2-pipe unit: 1 x valve kit + 1 x installation box for PCB KRP1BA101 + 1 x valve control PCB EKRPTC11  
4-pipe unit: 2 x valve kit + 1 x installation box for PCB KRP1BA101 + 1 x valve control PCB EKRPTC11
- \*11. This option is needed to create T1 T2 wire.
- \*12. It is possible to change the operation mode, but this will not have an impact on the water temperature.  
(No feed back to water source)  
It is not possible to select the "auto air flow" setting.  
Dry operation can be selected with this remote control, but this function is not available on the FWF model.
- \*13. All options are supplied as kit.

3TW33049-1A

# 5 Options

## 5 - 1 Options

### FWF-BT-BF

**Brief description of purpose of the available options:**

Item	Model	FWF02-05B	Description	
1 Decoration Panel (RAL 9010 - grey sealings)	4-way blow	BYFQ60B	Decoration panel for the fan coil unit that is built in the false sealing. Mandatory when installing the fan coil unit	
2 Sealing member of air discharge outlet		KDBH44BA60	This option can be used in case the fan coil unit is installed close to a wall on one or more sides (closer than 1500mm). With the blocking parts one more air outlets of the fan coil unit can be closed. --> Fan coil unit can be installed closer to a wall (but further than 200mm)	
3 Panel spacer		KDBQ44B60	Decorative spacer to fill the gap between panel and unit when the height of the suspended ceiling is too small.	
4 Long-life filter		KAFQ441BA60	High quality filter that can be used if supplied filter is damaged.	
5 Fresh air intake kit	Direct installation type	KDDQ44XA60	Kit that can be connected to the ventilation system to supply fresh air to the fan coil unit.	
6 Remote control	Infrared	H/P	BRC7E530	Infrared remote control to control each fan coil unit independently with cooling and heating functionality. It is not possible to select auto air flow with this remote control. Also there is no feedback regarding the operation mode to the "water supply unit".--> Changing the operation mode will not have an effect on the supplied water temperature. Dry operation can be selected, but the FWF unit does not have this function.
		C/O	BRC7E531	Infrared remote control to control each fan coil unit independently with cooling functionality. It is not possible to select auto air flow with this remote control. Also there is no feedback regarding the operation mode to the "water supply unit".--> Changing the operation mode will not have an effect on the supplied water temperature. Dry operation can be selected, but the FWF unit does not have this function.
	Wired	BRC315D7	Wired remote control to control each fan coil unit independently with cooling and heating functionality. There is no weekly timer function in this remote control. Only a limited on/off timer function is available. In case wires need to be installed inside the wall, the KJB212A installation box is required.	
7 Central remote control		DCS302CA51	Remote control for centralised control of all connected fan coil units (only FWF and FWC type).	
7.1 Electrical box with earth terminal (3 blocks)		KJB311A	Requires the KJB311A electrical installation box for the installation.	
8 Unified on/off controller		DCS301BA51	Remote control to switch all connected fan coil units (only FWC and FWF type) ON or OFF. In case unified on/off controller is built in the wall, the electrical box KJB212A kit is required.	
8.1 Electrical box with earth terminal (2 blocks)		KJB212A	For compliance reasons, the noise filter KEK26-1A is required in case a unified on/off controller is installed.	
9 Schedule timer		DST301BA51	Controller with schedule timer functionality for the fan coil units (only FWC and FWF). It is not possible to combine this option with KRP2A52 or KRP4AA53 or EKFCMBCB7 on the same fan coil unit. In case the schedule timer is built in the wall, the electrical box KJB212A is required.	
10 Intelligent touch controller		DCS601C51C	Advanced remote control for centralized control of all connected fan coil units (but only FWF and FWC type and up to 128 fan coil units). More functions are possible than with the central remote control. Compared to VRF systems, it's not possible to use AIRNET and telephone connection. The I-touch can not be used for installations with both DX units and fan coil units. The I-touch can not be used for installations with fan coil units that use Mod Bus communication.	
10.1 Electrical installation box		KJB411A	Electrical installation box KJB411A is needed for the installation of the I-touch remote control.	
11 Remote sensor		KRCS01-1	Sensor to measure the room temperature remotely from a location other than the fan coil unit or remote control.	
12 Remote "On/Off" and "forced off" kit		EKROROA	Option kit to allow a field supplied low voltage contact to control on/off operation of the fan coil unit. Example: to force the fan coil unit off, in case the window in the room is opened.	
13 2-way valve - On/Off		EKMV2C09B7	2-way valve to control the water supply to the fan coil unit. The option kit EKRP1C11 is needed to control the valve.	
14 3-way valve - On/Off		EKMV3C09B7	3-way valve to control the water supply to the fan coil unit. The option kit EKRP1C11 is needed to control the valve.	
15 Valve control PCB		EKR1C11	PCB to control the 2-way and 3-way valves. Only 1 option kit is needed per fan coil unit. It is possible to connect 2 valves on 1 PCB. For the installation of the PCB, the installation box KRP1BA101 is required.	
16 Optional PCB for MOD-bus connection		EKFCMBCB7	PCB to transform the DIII communication of the FWC and FWF fan coil units to Mod Bus RTU RS485 communication. For the installation of the PCB, the installation box KRP1BA101 is required. It's not possible to combine this option with KRP2A52 or KRP4AA53 or DST301BA51 on the same fan coil unit.	
17 Wiring adapter for electrical appendices (1)		KRP2A52	PCB with additional connection for external input/output signals. For the installation of the PCB, the installation box KRP1BA101 is required. It's not possible to combine this option with KRP4AA53 or EKFCMBCB7 or DST301BA51 on the same fan coil unit. Example of input signals: set point, on/off contact. Example of outputs: error stats of fan coil unit, operation status of fan coil unit (on/off). This PCB can control all FWC and FWF fan coil units connected on the same F1/F2 communication wire.	
18 Wiring adapter for electrical appendices (1)		KRP4AA53	PCB with additional connection for external input/output signals. For the installation of the PCB, the installation box KRP1BA101 is required. It's not possible to combine this option with KRP2A52 or EKFCMBCB7 or DST301BA51 on the same fan coil unit. Example of input signals: set point, on/off contact. Example of outputs: error stats of fan coil unit, operation status of fan coil unit (on/off). This PCB can control all FWC and FWF fan coil units connected on the same P1/P2 communication wire.	
19 Installation box for adapter PCB		KRP1BA101	Installation box for some option kits. Maximum 2 boxes can be installed on a single FWF unit.	

3TW33049-2A

# 6 Capacity tables

## 6 - 1 Cooling Capacity Tables

2  
6

Air temperature (°CDB - °CWB)		22-16															
Water temperature (Entering °C - Leaving °C)		6-11				7-12				8-13				9-14			
Model	Air flow	Total cooling capacity (kW)	Sensible cooling capacity (kW)	Water flow (l/min)	Water pressure drop (kPa)	Total cooling capacity (kW)	Sensible cooling capacity (kW)	Water flow (l/min)	Water pressure drop (kPa)	Total cooling capacity (kW)	Sensible cooling capacity (kW)	Water flow (l/min)	Water pressure drop (kPa)	Total cooling capacity (kW)	Sensible cooling capacity (kW)	Water flow (l/min)	Water pressure drop (kPa)
FWF02BT	HH	1.4	1.1	4.3	3	1.2	1.0	3.8	3	1.0	0.9	3.2	3	0.9	0.8	2.7	3
	H	1.2	0.9	3.7	3	1.0	0.8	3.1	3	0.9	0.8	2.6	2	0.8	0.7	2.2	2
	L	1.1	0.8	3.1	3	0.9	0.7	2.8	3	0.8	0.6	2.2	2	0.7	0.6	2.0	2
FWF03BT	HH	2.3	1.5	6.6	10	1.9	1.3	5.6	8	1.6	1.2	4.8	6	1.4	1.1	4.3	5
	H	2.0	1.2	5.8	8	1.7	1.1	5.1	7	1.4	1.0	4.3	5	1.2	1.0	3.7	4
	L	1.8	1.0	5.3	7	1.5	0.9	4.6	6	1.2	0.8	3.7	4	1.1	0.8	3.4	4
FWF04BT	HH	3.0	2.1	8.7	17	2.5	1.8	7.4	13	2.1	1.6	6.2	9	1.8	1.7	5.3	7
	H	2.4	1.6	7.0	12	2.0	1.4	5.8	8	1.7	1.3	5.0	7	1.5	1.2	4.4	5
	L	1.8	1.0	5.3	7	1.5	0.9	4.6	6	1.2	0.8	3.8	4	1.1	0.8	3.4	4
FWF05BT	HH	3.7	2.6	10.9	25	3.1	2.2	9.1	18	2.5	2.3	7.4	13	2.3	2.1	6.7	11
	H	2.8	2.0	8.2	15	2.4	1.7	7.1	12	2.0	1.6	5.9	9	1.7	1.6	5.1	7
	L	2.1	1.3	6.1	9	1.8	1.2	5.2	7	1.5	1.1	4.5	6	1.2	1.0	3.9	4

Air temperature (°CDB - °CWB)		25-18															
Water temperature (Entering °C - Leaving °C)		6-11				7-12				8-13				9-14			
Model	Air flow	Total cooling capacity (kW)	Sensible cooling capacity (kW)	Water flow (l/min)	Water pressure drop (kPa)	Total cooling capacity (kW)	Sensible cooling capacity (kW)	Water flow (l/min)	Water pressure drop (kPa)	Total cooling capacity (kW)	Sensible cooling capacity (kW)	Water flow (l/min)	Water pressure drop (kPa)	Total cooling capacity (kW)	Sensible cooling capacity (kW)	Water flow (l/min)	Water pressure drop (kPa)
FWF02BT	HH	1.9	1.4	5.5	5	1.6	1.3	4.8	5	1.5	1.2	4.6	4	1.3	1.0	4.1	3
	H	1.6	1.2	4.7	4	1.4	1.1	4.1	3	1.3	1.0	3.9	3	1.1	0.9	3.9	3
	L	1.4	1.0	4.2	4	1.3	0.9	3.7	3	1.2	0.9	4.1	3	1.0	0.8	3.9	3
FWF03BT	HH	3.0	1.8	8.7	17	2.7	1.7	8.0	14	2.4	1.6	7.2	12	2.1	1.4	6.2	9
	H	2.6	1.5	7.7	14	2.4	1.4	7.0	12	2.2	1.4	6.3	10	1.9	1.2	5.4	8
	L	2.3	1.3	6.8	11	2.1	1.2	6.3	10	2.0	1.1	5.7	8	1.6	1.0	5.0	7
FWF04BT	HH	3.9	2.6	11.4	27	3.6	2.4	10.4	23	3.2	2.2	9.4	19	2.7	2.0	8.0	14
	H	3.1	1.9	9.0	18	2.8	1.8	8.2	15	2.6	1.7	7.6	13	2.1	1.5	6.3	10
	L	2.4	1.3	6.9	11	2.1	1.2	6.2	9	2.0	1.1	5.7	8	1.7	1.0	5.0	7
FWF05BT	HH	4.9	3.2	14.2	40	4.5	3.0	13.1	34	4.1	2.8	11.9	29	3.5	2.5	10.1	22
	H	3.8	2.5	11.0	25	3.4	2.3	10.0	21	3.1	2.2	9.0	18	2.7	1.9	7.6	13
	L	2.7	1.6	7.9	14	2.5	1.5	7.3	12	2.2	1.4	6.6	10	1.9	1.3	5.6	8

**NOTES**

1.  The capacity is only guaranteed at the nominal conditions

3TW33042-2

Air temperature (°CDB - °CWB)		27-19															
Water temperature (Entering °C - Leaving °C)		6-11				7-12				8-13				9-14			
Model	Air flow	Total cooling capacity (kW)	Sensible cooling capacity (kW)	Water flow (l/min)	Water pressure drop (kPa)	Total cooling capacity (kW)	Sensible cooling capacity (kW)	Water flow (l/min)	Water pressure drop (kPa)	Total cooling capacity (kW)	Sensible cooling capacity (kW)	Water flow (l/min)	Water pressure drop (kPa)	Total cooling capacity (kW)	Sensible cooling capacity (kW)	Water flow (l/min)	Water pressure drop (kPa)
FWF02BT	HH	2.1	1.5	6.1	6	2.0	1.5	6.0	6	1.7	1.4	5.2	5	1.5	1.3	4.7	4
	H	1.8	1.3	5.4	5	1.7	1.3	4.9	4	1.5	1.2	4.3	4	1.3	1.1	4.1	3
	L	1.6	1.1	4.8	4	1.5	1.1	4.3	4	1.3	1.0	4.0	3	1.2	0.9	3.6	3
FWF03BT	HH	3.4	2.1	10.0	21	3.2	2	9.4	19	2.8	1.8	8.3	15	2.6	1.7	7.5	13
	H	3.0	1.7	8.8	17	2.8	1.7	8.0	14	2.5	1.6	7.3	12	2.3	1.5	6.7	11
	L	2.7	1.4	7.8	14	2.5	1.4	7.2	12	2.2	1.3	6.5	10	2.0	1.2	6.0	9
FWF04BT	HH	4.5	2.9	13.1	34	4.2	2.8	12.4	31	3.7	2.6	10.7	24	3.4	2.4	9.8	20
	H	3.5	2.2	10.3	22	3.3	2.1	9.5	19	2.9	1.9	8.6	16	2.6	1.8	7.8	14
	L	2.7	1.4	7.8	14	2.5	1.4	7.2	12	2.2	1.3	6.5	10	2.0	1.2	6.0	9
FWF05BT	HH	5.6	3.7	16.2	50	5.2	3.5	14.7	42	4.7	3.3	13.4	36	4.3	3.0	12.4	31
	H	4.3	2.8	12.7	32	4.0	2.7	11.5	27	3.6	2.5	10.4	23	3.2	2.3	9.4	19
	L	3.1	1.9	9.0	18	2.9	1.8	8.3	15	2.6	1.7	7.6	13	2.3	1.5	6.8	11

Air temperature (°CDB - °CWB)		30-22															
Water temperature (Entering °C - Leaving °C)		6-11				7-12				8-13				9-14			
Model	Air flow	Total cooling capacity (kW)	Sensible cooling capacity (kW)	Water flow (l/min)	Water pressure drop (kPa)	Total cooling capacity (kW)	Sensible cooling capacity (kW)	Water flow (l/min)	Water pressure drop (kPa)	Total cooling capacity (kW)	Sensible cooling capacity (kW)	Water flow (l/min)	Water pressure drop (kPa)	Total cooling capacity (kW)	Sensible cooling capacity (kW)	Water flow (l/min)	Water pressure drop (kPa)
FWF02BT	HH	3.0	1.8	8.7	11	2.8	1.7	8.2	10	2.6	1.6	7.5	9	2.3	1.5	6.8	7
	H	2.6	1.6	7.8	9	2.4	1.5	7.2	8	2.2	1.4	6.7	7	2.1	1.3	6.0	6
	L	2.3	1.3	6.8	7	2.1	1.2	6.3	7	2.0	1.2	5.8	6	1.8	1.1	5.3	5
FWF03BT	HH	4.8	2.4	13.7	37	4.5	2.3	13.0	34	4.2	2.2	12.2	30	3.9	2.1	11.3	26
	H	4.2	2.0	12.0	29	3.9	2.0	11.5	27	3.7	1.9	10.7	24	3.4	1.8	9.8	20
	L	3.7	1.7	10.6	24	3.5	1.6	10.0	21	3.3	1.5	9.5	19	3.0	1.4	8.8	17
FWF04BT	HH	6.3	3.4	18.0	61	5.9	3.2	17.0	55	5.5	3.1	16.1	50	5.1	2.9	15.0	44
	H	4.9	2.5	14.2	40	4.6	2.4	13.5	36	4.3	2.3	12.7	32	4.0	2.2	11.6	28
	L	3.7	1.7	10.8	24	3.5	1.6	10.0	21	3.3	1.5	9.5	19	3.0	1.4	8.8	17
FWF05BT	HH	7.8	4.5	22.7	94	7.3	4.1	21.3	83	6.9	3.9	20.0	74	6.5	3.7	18.8	66
	H	6.1	3.3	17.6	59	5.7	3.1	16.6	53	5.3	3.0	15.4	46	4.9	2.8	14.4	41
	L	4.3	2.2	12.6	32	4.1	2.1	11.8	28	3.8	2.0	11.0	25	3.5	1.9	10.2	22

**NOTES**

1.  The capacity is only guaranteed at the nominal conditions

3TW33042-2

## 6 Capacity tables

### 6 - 2 Heating Capacity Tables

#### FWF-BT

Air temperature (°CDB)		20		
Water temperature (Entering °C)		50-45		
Model	Airflow	Heating capacity (kW)	Water flow (l/min)	Water pressure drop (kPa)
FWF02BT	HH	2.9	6.0	6
	H	2.6	4.9	4
	L	2.3	4.3	4
FWF03BT	HH	4.0	9.4	19
	H	3.4	8.0	14
	L	2.8	7.2	12
FWF04BT	HH	5.4	12.4	31
	H	4.1	9.5	19
	L	2.8	7.2	12
FWF05BT	HH	6.7	14.7	42
	H	5.3	11.5	27
	L	3.6	8.3	15

Air temperature (°CDB)		22		
Water temperature (Entering °C)		50-45		
Model	Airflow	Heating capacity (kW)	Water flow (l/min)	Water pressure drop (kPa)
FWF02BT	HH	2.7	6.0	6
	H	2.4	4.9	4
	L	2.1	4.3	4
FWF03BT	HH	3.7	9.4	19
	H	3.1	8.0	14
	L	2.6	7.2	12
FWF04BT	HH	5.0	12.4	31
	H	3.8	9.5	19
	L	2.6	7.2	12
FWF05BT	HH	6.2	14.7	42
	H	4.9	11.5	27
	L	3.3	8.3	15

3TW33042-1

#### NOTE

- The water flow is the same as for cooling mode in the nominal point. Delta T is not fixed.

# 7 Dimensional drawings

## 7 - 1 Dimensional Drawings

2  
7

FWF-BT/BF

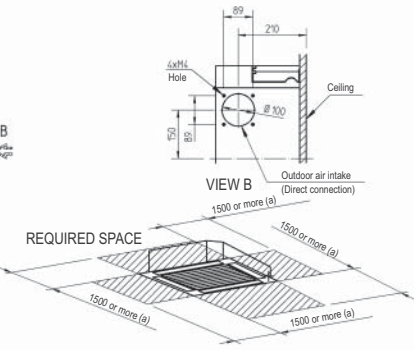
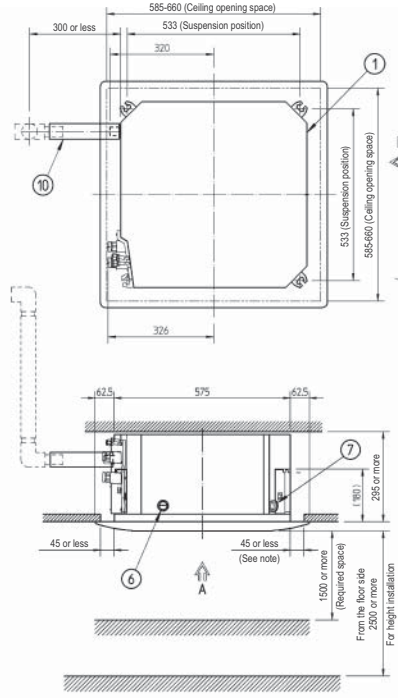
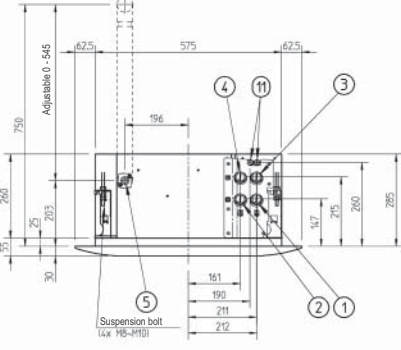
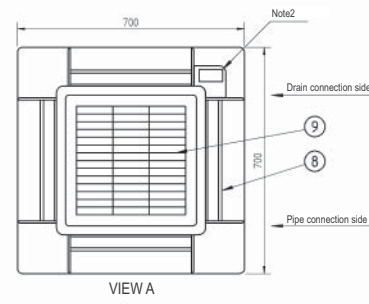

(a) When the discharge grille is covered (by an option kit) the required space is 200mm or more

Nr	Part name	Remark
1	Water pipe connection cooling in	3/4" BSP female (For FWF_B7T: water in)
2	Water pipe connection cooling out	3/4" BSP female (For FWF_B7T: water out)
3	Water pipe connection heating in	3/4" BSP female (For FWF-B7F)
4	Water pipe connection heating out	3/4" BSP female (For FWF-B7F)
5	Drain pipe connection	VP20 (O.D. Ø26)
6	Power supply entry hole	.
7	Transmission wiring entry hole	.
8	Air discharge grille	.
9	Suction grille	.
10	Drain hose (accessory)	1.D.Ø25 (Outlet)
11	Air purge	(1 for FWF_B7T, 2 for FWF_B7F)

DECORATION PANEL

BYFQ60B	White RAL 9010
---------	----------------

3TW33044-1

**NOTES**

1. Sticking location for manufacturer's label: For indoor unit: on the bell mouth inside suction grille. For decoration panel: on the inner frame inside suction grille.
2. In case of using Infrared remote control, this position will be a signal receiver. Refer to drawing of Infrared remote control for details.
3. When the temperature and humidity in the ceiling exceeds 30°C and RH 80% or the fresh air is inducted into the ceiling or the unit continues 24 hours operation, an additional insulation is required. (Thickness 10mm or more of glaswool or PE foam)
4. Though the installation is acceptable up to maximum of 660 mm square ceiling opening, keep a clearance of 45 mm or less between the main unit and the ceiling opening, so that the panel overlap can be ensured.

# 7 Dimensional drawings

## 7 - 2 Dimensional Drawings with Accessories

FWF-BT-BF

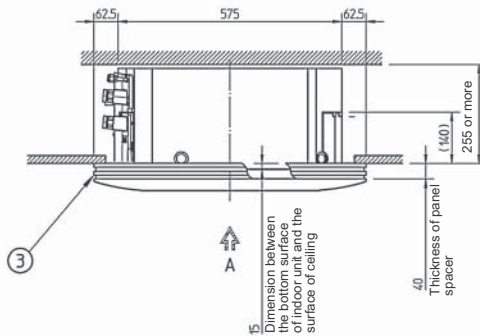
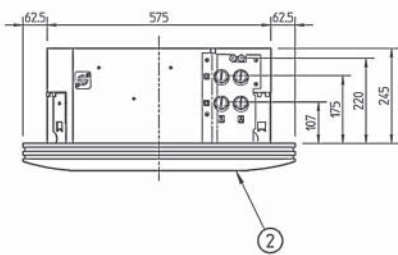
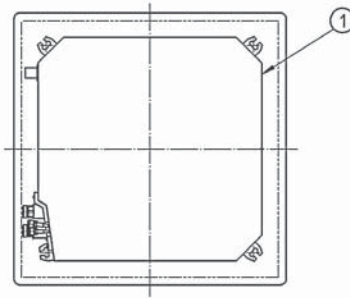
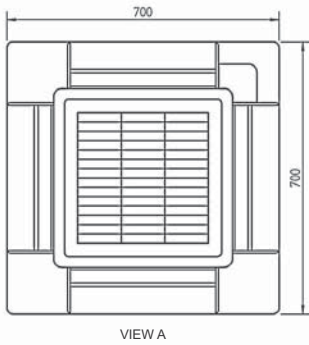

ITEM	PART NAME	REMARK
1	Indoor unit	-
2	Decoration panel	-
3	Panel spacer	-

**NOTE**

1. Number of pipe connections and air purges is depending on model type.

3TW33044-2

## 8 Centre of gravity

### 8 - 1 Centre of Gravity

FWF-BT/BF

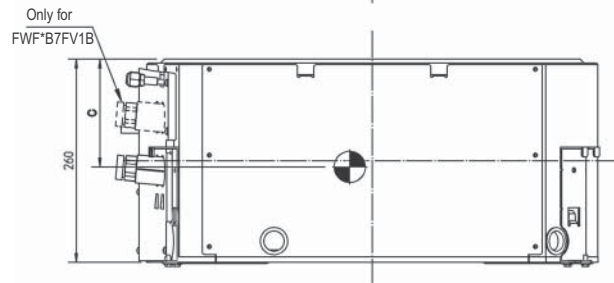
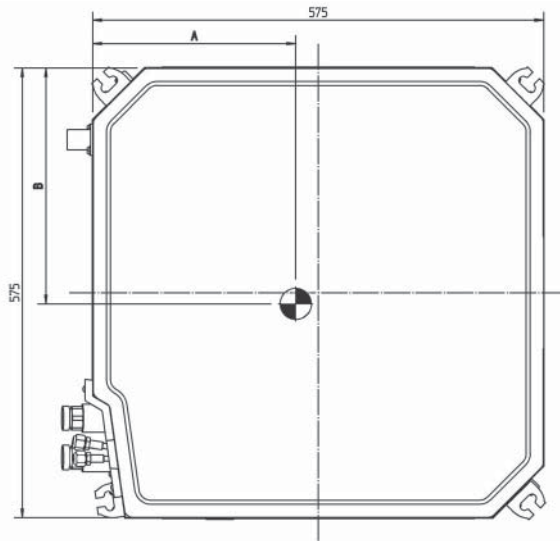

Model	A	B	C
FWF02B7TV1B	259	295	133
FWF02B7FV1B	256	300	132
FWF03-05B7TV1B	267	301	130
FWF03-05B7FV1B	257	312	135

4TW33044-3

# 9 Piping diagrams

## 9 - 1 Piping Diagrams

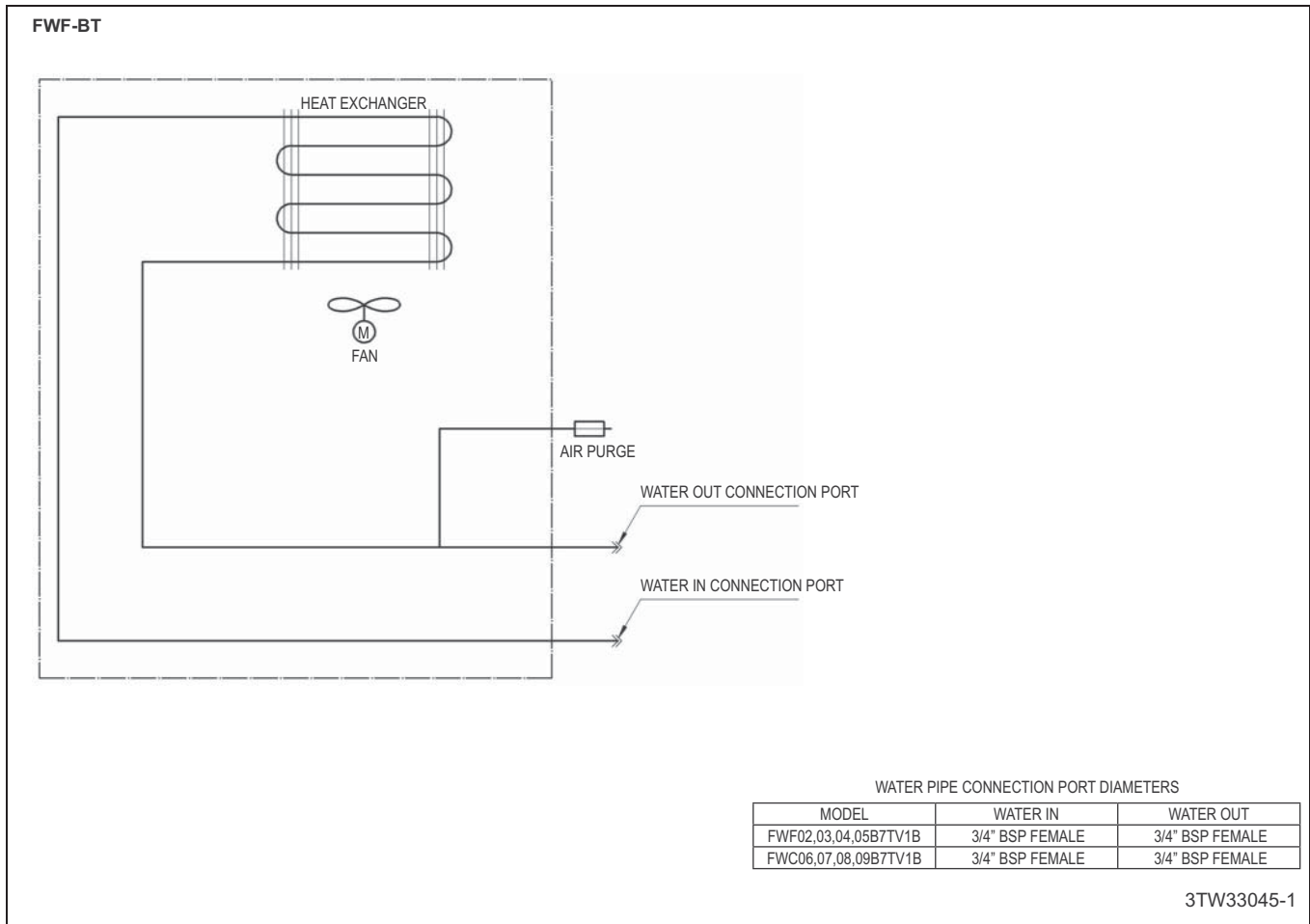

# 10 Sound data

## 10 - 1 Sound Power Spectrum

2  
10

FWF02-03BT, FWF02BF

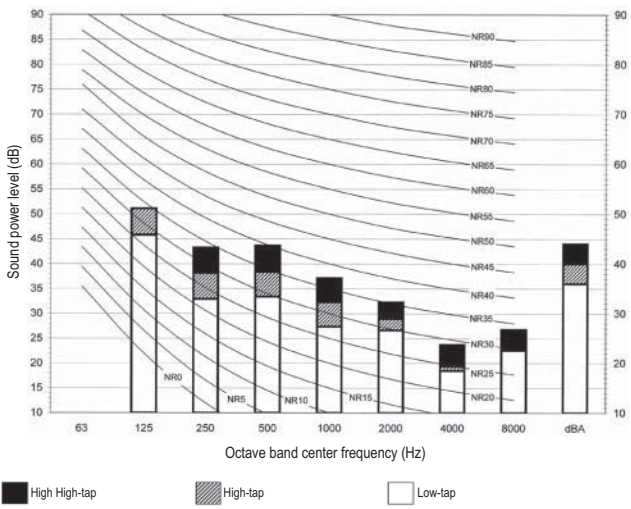

3TW33047-1A

**NOTES**

1. dBA = A-weighted sound pressure level. (A-scale according to IEC)
2. Reference acoustic pressures 0dB = 10E-6μW/m<sup>2</sup>
3. Measured according to ISO 3744

FWF04BT

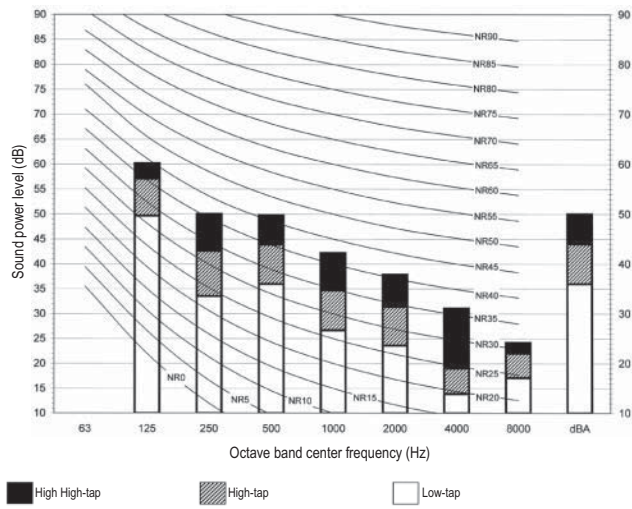

3TW33067-1A

**NOTES**

1. dBA = A-weighted sound pressure level. (A-scale according to IEC)
2. Reference acoustic pressures 0dB = 10E-6μW/m<sup>2</sup>
3. Measured according to ISO 3744

FWF05BT

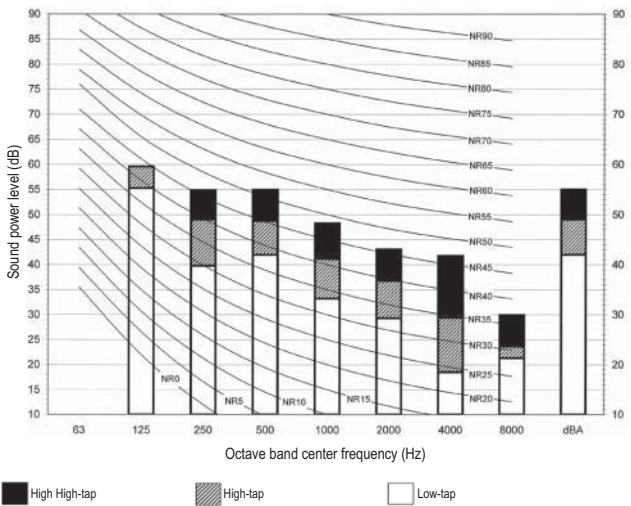

3TW33077-1A

**NOTES**

1. dBA = A-weighted sound pressure level. (A-scale according to IEC)
2. Reference acoustic pressures 0dB = 10E-6μW/m<sup>2</sup>
3. Measured according to ISO 3744

# 10 Sound data

## 10 - 2 Sound Pressure Spectrum

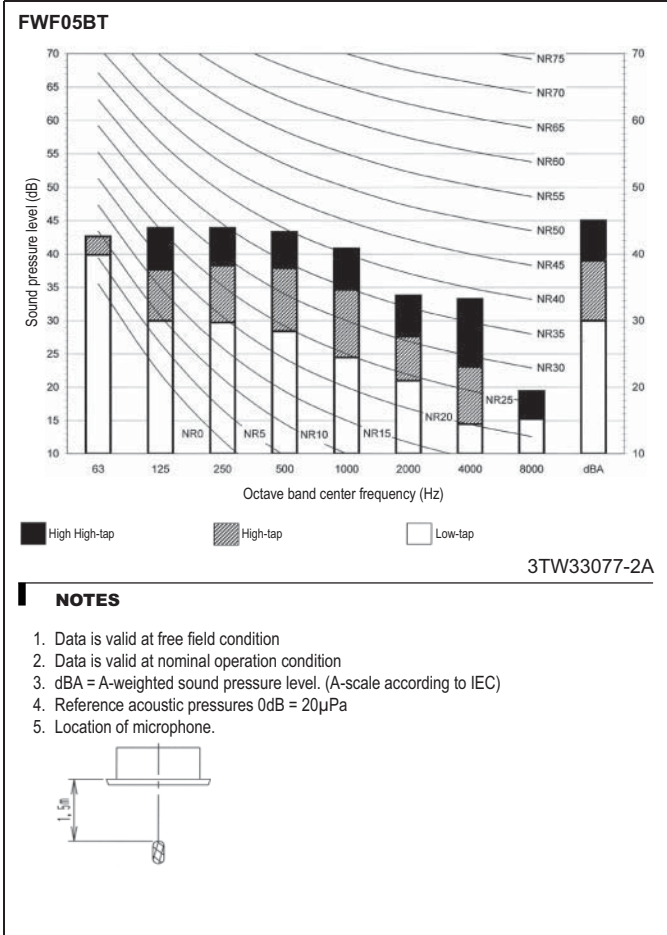
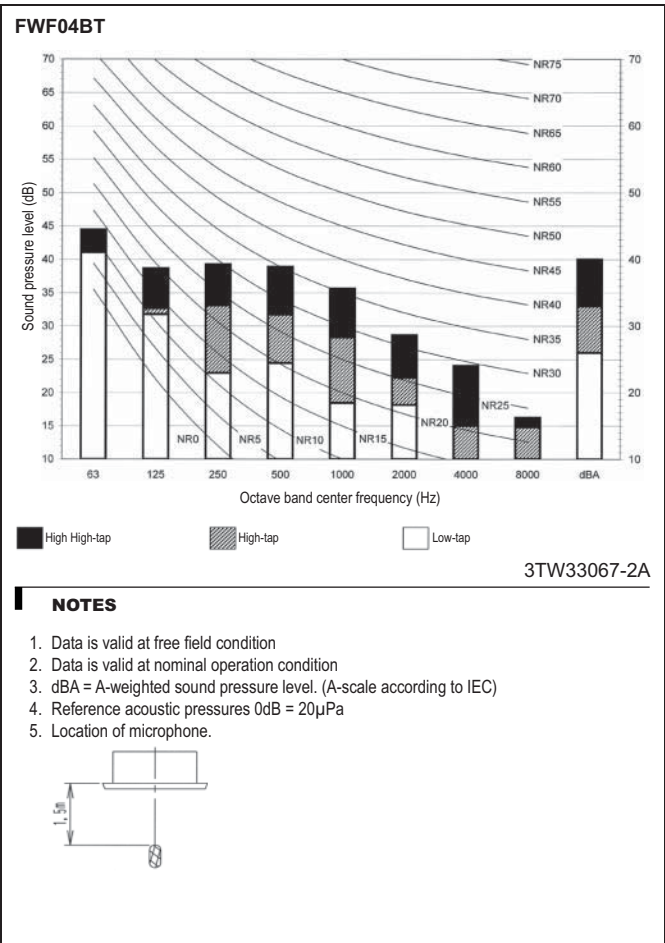
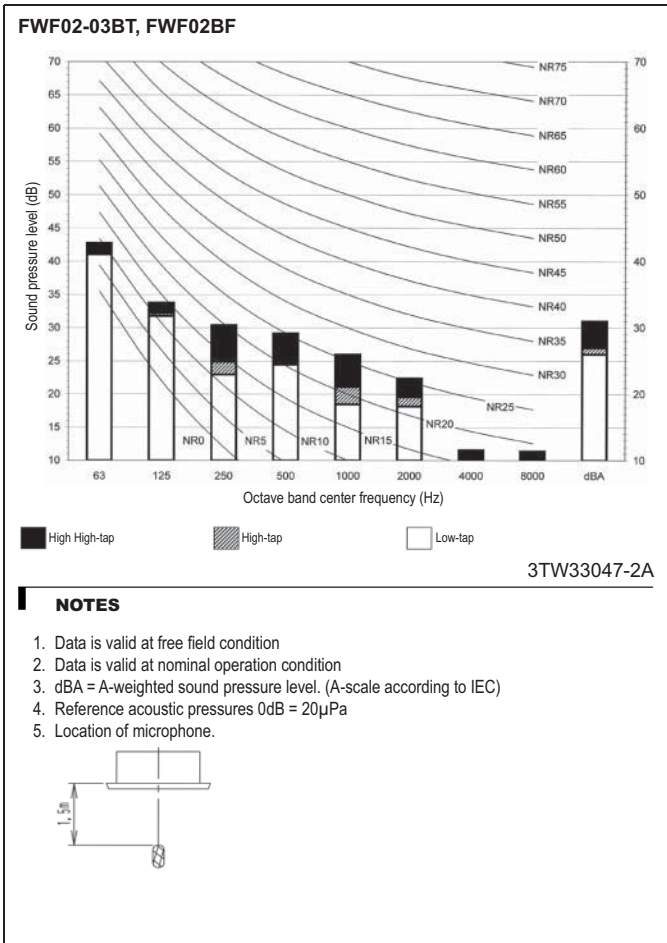

# 11 Hydraulic performance

## 11 - 1 Water Pressure Drop Curve Evaporator

2  
11

FWF-BT

Pressure drop over FWF02B7TV1B

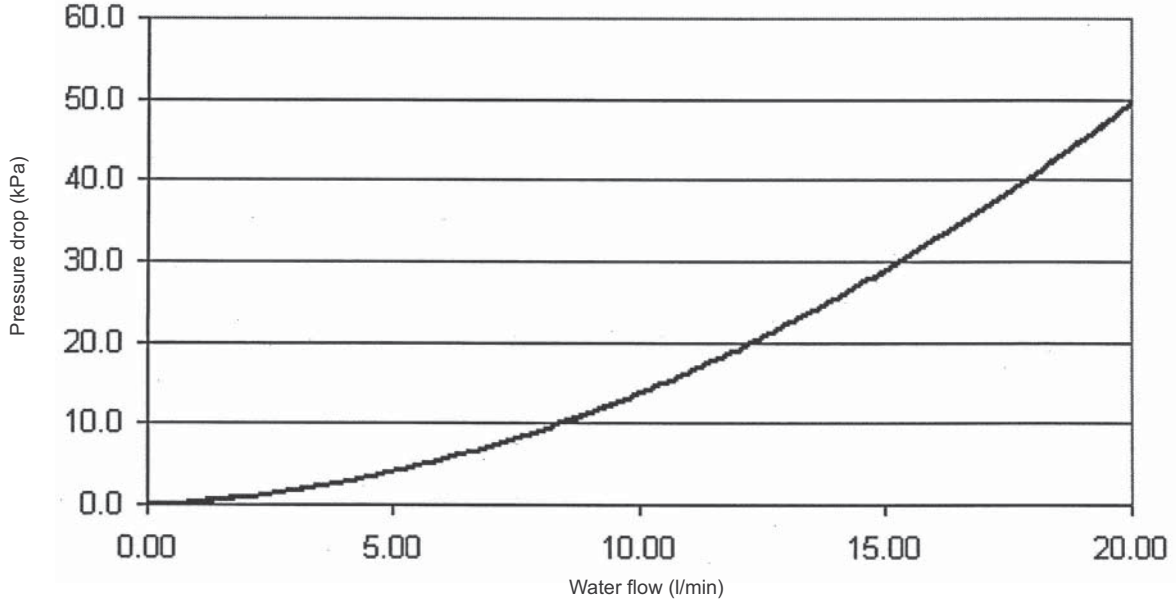

4TW33049-5

**NOTE**

1. This graph can be used to calculate the pressure drop over the fan coil unit. The pressure drop over the valve is not included.

FWF-BT

Pressure drop over FWF03-05B7TV1B

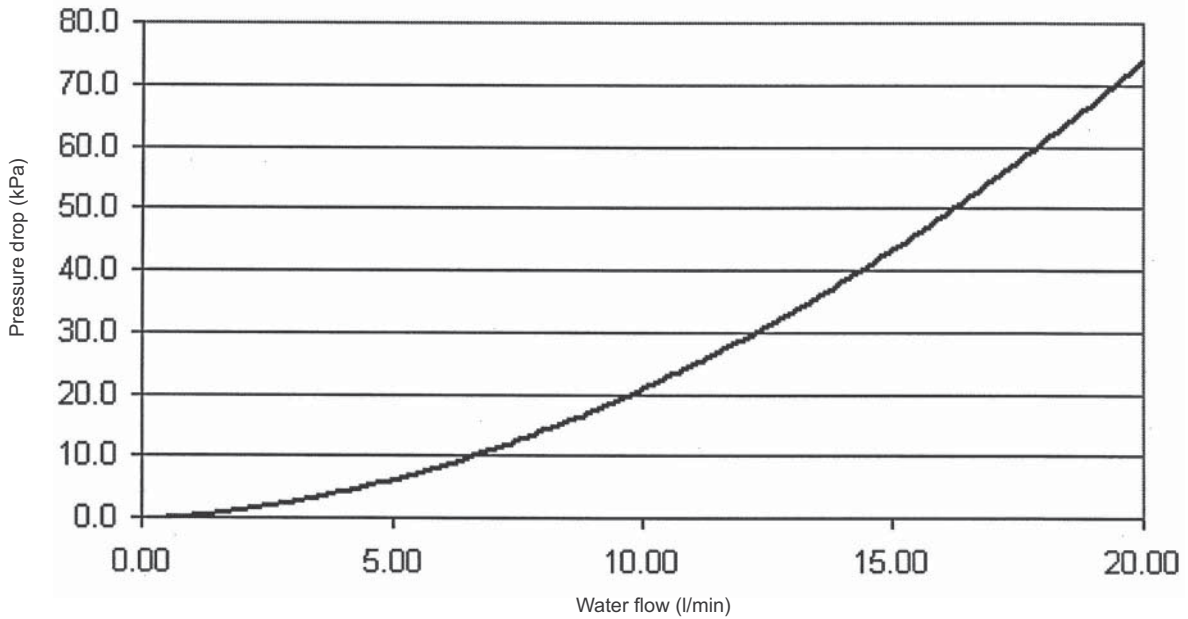

4TW33059-5

**NOTE**

1. This graph can be used to calculate the pressure drop over the fan coil unit. The pressure drop over the valve is not included.

# TABLE OF CONTENTS

## FWF-BF

1	Features .....	56
2	Specifications .....	57
	Technical Specifications .....	57
	Electrical Specifications .....	57
3	Electrical data .....	58
	Electrical Data .....	58
4	Safety device settings .....	59
	Safety Device Settings .....	59
5	Options .....	60
	Options .....	60
6	Capacity tables .....	62
	Cooling Capacity Tables .....	62
	Heating Capacity Tables .....	63
7	Dimensional drawings .....	64
	Dimensional Drawings .....	64
	Dimensional Drawings with Accessories .....	65
8	Centre of gravity .....	66
	Centre of Gravity .....	66
9	Piping diagrams .....	67
	Piping Diagrams .....	67
10	Sound data .....	68
	Sound Power Spectrum .....	68
	Sound Pressure Spectrum .....	69
11	Hydraulic performance .....	70
	Water Pressure Drop Curve Evaporator .....	70

# 1 Features

- Modern style decoration panel in white (RAL9010)
- Compact casing (570mm in width and depth) enables unit to fit flush into ceilings and match standard architectural modules, without cutting ceiling tiles
- Comfortable horizontal auto swing ensures draughtfree operation and prevents ceiling soiling
- Fresh air intake for healthy living
- Possibility to shut 1 or 2 flaps for easy installation in corners
- Standard drain pump with 750mm lift



2

1

## 2 Specifications

2-1 Technical Specifications				FWF02BF	FWF03BF	FWF04BF	FWF05BF
Cooling capacity	Total capacity	Super high	kW	2.0 (1)	2.7 (1)	3.5 (1)	4.5 (1)
		High	kW	1.7 (1)	2.3 (1)	2.8 (1)	3.5 (1)
		Low	kW	1.4 (1)	1.8 (1)		2.6 (1)
	Sensible capacity	Super high	kW	1.5 (1)	1.7 (1)	2.4 (1)	3.3 (1)
		High	kW	1.3 (1)		1.7 (1)	2.3 (1)
		Low	kW	1.1 (1)	1.0 (1)		1.5 (1)
Heating capacity	4-Pipe	Super high	kW	3.9 (3)	3.8 (3)	4.9 (3)	6.1 (3)
		High	kW	3.1 (3)	3.3 (3)	3.9 (3)	4.8 (3)
		Low	kW	2.3 (3)	2.8 (3)		3.5 (3)
Power input	Super high	W	74		94	121	
	High	W	67	62	74	93	
	Low	W	60	55		66	
Casing	Material		Galvanised steel plate				
Dimensions	Unit	Height	mm	285			
		Width	mm	575			
		Depth	mm	575			
Weight	Unit	kg	19	20			
Heat exchanger	Rows	Quantity	2	3			
	Fin pitch		mm	1.5			
Water pressure drop	Cooling	kPa	6	13	21	33	
	Heating	kPa	12	6	9	13	
Fan	Type		Turbo fan				
	Quantity		1				
	Air flow rate	High	m <sup>3</sup> /h	468	438	618	822
		Medium	m <sup>3</sup> /h	390	366	456	612
Low		m <sup>3</sup> /h	318	300		390	
Fan motor	Speed	Steps	3				
	Model		QTS32C15M				
Sound power level	Super high	dBA	44	46	52	57	
	High	dBA	40	42	46	51	
	Low	dBA	36	38		44	
Sound pressure level	Super high	dBA	31	33	42	47	
	High	dBA	27	29	35	41	
	Low	dBA	26	27		32	
Insulation material			Foamed polystyrene / foamed polyethylene				

Standard Accessories : Screws;

Standard Accessories : Drain hose;

Standard Accessories : O ring;

Standard Accessories : Insulation;

Standard Accessories : Installation guide;

Standard Accessories : Washer for hanger bracket;

Standard Accessories : Clamp for drain hose;

Standard Accessories : Installation and operation manual;

2-2 Electrical Specifications			FWF02BF	FWF03BF	FWF04BF	FWF05BF
Power supply	Phase		1~			
	Frequency	Hz	50			
	Voltage	V	220-440			

### Notes

(1) Cooling: air 27°CDB, 19°CWB; entering water 7°C; leaving water 12°C

(2) Heating: 4 pipe: air 20°CDB; entering water 70°C; leaving water 60°C

(3) Do not let water of less than 5°C or more than 50°/70°C enter the unit, this may damage the unit

(4) Height includes switch box

### 3 Electrical data

#### 3 - 1 Electrical Data

**FWF-BT-BF**

UNITS					POWER SUPPLY		IFM		INPUT (W)	
MODEL	TYPE	Hz	VOLTAGE RANGE	VOLTAGE LIMITS	MCA	MFA	kW	FLA	COOLING	HEATING
FWF02BT	V1	50	220-240	MAX. 264 MIN. 198	0.6	16	0.055	0.5	74	74
FWF03BT					0.6	16	0.055	0.5	74	74
FWF04BT					0.7	16	0.055	0.6	90	90
FWF05BT					0.8	16	0.055	0.7	118	118
FWF02BF	V1	50	220-240	MAX. 242 MIN. 198	0.6	16	0.055	0.5	74	74
FWF03BF					0.6	16	0.055	0.5	74	74
FWF04BF					0.7	16	0.055	0.6	94	94
FWF05BF					0.8	16	0.055	0.7	121	121

Symbols:

- MCA: Min Circuit Amps (A)
- MFA: Max. Fuse Amps (See note 5)
- kW: FAN Motor Rated Output (kW)
- FLA: Full Load Amps (A)
- IFM: Indoor Fan Motor

**NOTES**

1. Voltage limits:  
Units are suitable for use on electrical systems where voltage supplied to unit terminals is not below or above listed range limits.
2. Maximum allowable voltage unbalanced between phases is 2%.
3. MCA/MFA  
MCA = 1.25 x FLA  
MFA <= 4 x FLA  
(Next lower standard fuse rating min. 16A)
4. Select wire size based on the MCA.
5. Instead of fuse, use Circuit Breaker.

4TW33041-2

2  
3

## 4 Safety device settings

### 4 - 1 Safety Device Settings

FWF-BT-BF

		Safety devices	02	03	04	05
FWF-BF/BT	PC board fuse		250V 5A			
	Fan motor thermal fuse	°C	---			
	Fan motor thermal protector	°C	OFF: 130±5 ON: 83±20			

4TW33049-4

2

4

# 5 Options

## 5 - 1 Options

2  
5

### FWF-BT/BF

#### Options

Item	Model	FWF02-05B
1	Decoration Panel (RAL 9010 - grey sealings)	4-way blow BYFQ60B
2	Sealing member of air discharge outlet	KDBH44BA60
3	Panel spacer	KDBQ44B60
4	Long-life filter	KAFQ441BA60
5	Fresh air intake kit	Direct installation type KDDQ44XA60

#### Control system

Item	Model	FWF02-05B	
1	Remote control	Infrared	
		H/P	BRC7E530 (*12)
		C/O	BRC7E531 (*12)
	Wired	BRC315D7 (*1)	
2	Central remote control	DCS302CA51 (*2)	
2.1	Electrical box with earth terminal (3 blocks)	KJB311A	
3	Unified on/off controller	DCS301BA51 (*5)	
3.1	Electrical box with earth terminal (2 blocks)	KJB212A	
4	Schedule timer	DST301BA51 (*5)(*8)	
5	Wiring adapter for electrical appendices (1)	KRP2A52 (*4)(*8)	
6	Wiring adapter for electrical appendices (2)	KRP4AA53 (*4)(*8)	
7	Installation box for adapter PCB	KRP1BA101 (*9)	
8	Remote sensor	KRCS01-1	
10	Intelligent touch controller	DCS601C51C (*3)(*7)	
10.1	Electrical installation box	KJB411A	
11	Optional PCB for MOD-bus connection	EKFCMBCB7 (*4)(*8)	
12	2-way valve - On/Off	EKMV2C09B7 (*4)(*6)(*10)	
13	3-way valve - On/Off	EKMV3C09B7 (*4)(*6)(*10)	
14	Valve control PCB	EKRPTC11	
15	Remote "On/Off" and "forced off" kit	EKROROA (*11)	

#### NOTES

- \*1. Optional, electrical installation box with earth terminal KJB212A is required, if controller wires need to be installed in the wall.
- \*2. Requires electrical installation box with earth terminal KJB311A.
- \*3. Requires electrical installation box KJB411A.
- \*4. Requires installation box KRP1BA101.
- \*5. Requires electrical installation box with earth terminal KJB212A if built in the wall.
- \*6. Requires valve control PCB EKRP1C11.
- \*7. I-touch:
  - Not allowed to use the i-touch for an installation with both fan coils and VRV® units.
  - Can not be used in combination with fan coil units, that use MOD bus communication.
  - No Airnet or telephone connection possible.
- \*8. Only 1 of these 4 options can be installed on 1 indoor unit.
- \*9. Max. 2 KRP1BA101 boxes can be mounted on the unit. Max. 1 PCB can be mounted in 1 KRP1BA101 box.
- \*10. 2-pipe unit: 1 x valve kit + 1 x installation box for PCB KRP1BA101 + 1 x valve control PCB EKRP1C11  
4-pipe unit: 2 x valve kit + 1 x installation box for PCB KRP1BA101 + 1 x valve control PCB EKRP1C11
- \*11. This option is needed to create T1 T2 wire.
- \*12. It is possible to change the operation mode, but this will not have an impact on the water temperature.  
(No feed back to water source)  
It is not possible to select the "auto air flow" setting.  
Dry operation can be selected with this remote control, but this function is not available on the FWF model.
- \*13. All options are supplied as kit.

3TW33049-1A

# 5 Options

## 5 - 1 Options

### FWF-BT-BF

**Brief description of purpose of the available options:**

Item	Model	FWF02-05B	Description	
1 Decoration Panel (RAL 9010 - grey sealings)	4-way blow	BYFQ60B	Decoration panel for the fan coil unit that is built in the false sealing. Mandatory when installing the fan coil unit	
2 Sealing member of air discharge outlet		KDBH44BA60	This option can be used in case the fan coil unit is installed close to a wall on one or more sides (closer than 1500mm). With the blocking parts one more air outlets of the fan coil unit can be closed. --> Fan coil unit can be installed closer to a wall (but further than 200mm)	
3 Panel spacer		KDBQ44B60	Decorative spacer to fill the gap between panel and unit when the height of the suspended ceiling is too small.	
4 Long-life filter		KAFQ441BA60	High quality filter that can be used if supplied filter is damaged.	
5 Fresh air intake kit	Direct installation type	KDDQ44XA60	Kit that can be connected to the ventilation system to supply fresh air to the fan coil unit.	
6 Remote control	Infrared	H/P	BRC7E530	Infrared remote control to control each fan coil unit independently with cooling and heating functionality. It is not possible to select auto air flow with this remote control. Also there is no feedback regarding the operation mode to the "water supply unit".--> Changing the operation mode will not have an effect on the supplied water temperature. Dry operation can be selected, but the FWF unit does not have this function.
		C/O	BRC7E531	Infrared remote control to control each fan coil unit independently with cooling functionality. It is not possible to select auto air flow with this remote control. Also there is no feedback regarding the operation mode to the "water supply unit".--> Changing the operation mode will not have an effect on the supplied water temperature. Dry operation can be selected, but the FWF unit does not have this function.
	Wired	BRC315D7	Wired remote control to control each fan coil unit independently with cooling and heating functionality. There is no weekly timer function in this remote control. Only a limited on/off timer function is available. In case wires need to be installed inside the wall, the KJB212A installation box is required.	
7 Central remote control		DCS302CA51	Remote control for centralised control of all connected fan coil units (only FWF and FWC type).	
7.1 Electrical box with earth terminal (3 blocks)		KJB311A	Requires the KJB311A electrical installation box for the installation.	
8 Unified on/off controller		DCS301BA51	Remote control to switch all connected fan coil units (only FWF and FWC type) ON or OFF. In case unified on/off controller is built in the wall, the electrical box KJB212A kit is required.	
8.1 Electrical box with earth terminal (2 blocks)		KJB212A	For compliance reasons, the noise filter KEK26-1A is required in case a unified on/off controller is installed.	
9 Schedule timer		DST301BA51	Controller with schedule timer functionality for the fan coil units (only FWC and FWF). It is not possible to combine this option with KRP2A52 or KRP4AA53 or EKFCMBCB7 on the same fan coil unit. In case the schedule timer is built in the wall, the electrical box KJB212A is required.	
10 Intelligent touch controller		DCS601C51C	Advanced remote control for centralized control of all connected fan coil units (but only FWF and FWC type and up to 128 fan coil units). More functions are possible than with the central remote control. Compared to VRV systems, it's not possible to use AIRNET and telephone connection. The I-touch can not be used for installations with both DX units and fan coil units. The I-touch can not be used for installations with fan coil units that use Mod Bus communication.	
10.1 Electrical installation box		KJB411A	Electrical installation box KJB411A is needed for the installation of the I-touch remote control.	
11 Remote sensor		KRCS01-1	Sensor to measure the room temperature remotely from a location other than the fan coil unit or remote control.	
12 Remote "On/Off" and "forced off" kit		EKROROA	Option kit to allow a field supplied low voltage contact to control on/off operation of the fan coil unit. Example: to force the fan coil unit off, in case the window in the room is opened.	
13 2-way valve - On/Off		EKMV2C09B7	2-way valve to control the water supply to the fan coil unit. The option kit EKRP1C11 is needed to control the valve.	
14 3-way valve - On/Off		EKMV3C09B7	3-way valve to control the water supply to the fan coil unit. The option kit EKRP1C11 is needed to control the valve.	
15 Valve control PCB		EKR1C11	PCB to control the 2-way and 3-way valves. Only 1 option kit is needed per fan coil unit. It is possible to connect 2 valves on 1 PCB. For the installation of the PCB, the installation box KRP1BA101 is required.	
16 Optional PCB for MOD-bus connection		EKFCMBCB7	PCB to transform the DIII communication of the FWC and FWF fan coil units to Mod Bus RTU RS485 communication. For the installation of the PCB, the installation box KRP1BA101 is required. It's not possible to combine this option with KRP2A52 or KRP4AA53 or DST301BA51 on the same fan coil unit.	
17 Wiring adapter for electrical appendices (1)		KRP2A52	PCB with additional connection for external input/output signals. For the installation of the PCB, the installation box KRP1BA101 is required. It's not possible to combine this option with KRP4AA53 or EKFCMBCB7 or DST301BA51 on the same fan coil unit. Example of input signals: set point, on/off contact. Example of outputs: error stats of fan coil unit, operation status of fan coil unit (on/off). This PCB can control all FWC and FWF fan coil units connected on the same F1/F2 communication wire.	
18 Wiring adapter for electrical appendices (1)		KRP4AA53	PCB with additional connection for external input/output signals. For the installation of the PCB, the installation box KRP1BA101 is required. It's not possible to combine this option with KRP2A52 or EKFCMBCB7 or DST301BA51 on the same fan coil unit. Example of input signals: set point, on/off contact. Example of outputs: error stats of fan coil unit, operation status of fan coil unit (on/off). This PCB can control all FWC and FWF fan coil units connected on the same P1/P2 communication wire.	
19 Installation box for adapter PCB		KRP1BA101	Installation box for some option kits. Maximum 2 boxes can be installed on a single FWF unit.	

3TW33049-2A

# 6 Capacity tables

## 6 - 1 Cooling Capacity Tables

2  
6

Air temperature (°CDB - °CWB)		22-16															
Water temperature (Entering °C - Leaving °C)		6-11				7-12				8-13				9-14			
Model	Air flow	Total cooling capacity (kW)	Sensible cooling capacity (kW)	Water flow (l/min)	Water pressure drop (kPa)	Total cooling capacity (kW)	Sensible cooling capacity (kW)	Water flow (l/min)	Water pressure drop (kPa)	Total cooling capacity (kW)	Sensible cooling capacity (kW)	Water flow (l/min)	Water pressure drop (kPa)	Total cooling capacity (kW)	Sensible cooling capacity (kW)	Water flow (l/min)	Water pressure drop (kPa)
FWF02BF	HH	1.4	1.1	4.1	3	1.1	1.0	3.5	2	1.0	0.9	3.1	2	0.8	0.8	2.6	2
	H	1.2	0.9	3.7	2	1.0	0.8	3.0	2	0.9	0.8	2.6	2	0.7	0.7	2.2	2
	L	1.0	0.8	3.0	2	0.8	0.7	2.5	2	0.7	0.7	2.3	2	0.6	0.6	1.8	2
FWF03BF	HH	1.9	1.2	5.7	10	1.6	1.1	5.6	8	1.4	1.0	4.1	6	1.1	1.0	4.3	5
	H	1.6	0.9	4.8	8	1.4	0.8	5.1	7	1.2	0.8	3.4	5	1.0	0.7	3.1	4
	L	1.2	0.7	3.8	7	1.0	0.6	4.6	6	1.1	0.6	2.8	4	0.7	0.6	2.5	4
FWF04BF	HH	2.4	1.7	7.1	17	2.0	1.5	7.4	13	1.8	1.4	5.3	9	1.5	1.4	5.3	7
	H	1.9	1.2	5.7	12	1.7	1.1	5.8	8	1.4	1.0	4.2	7	1.2	1.0	4.4	5
	L	1.3	0.7	3.8	7	1.1	0.6	4.6	6	1.1	0.6	2.8	4	0.7	0.6	2.5	4
FWF05BF	HH	3.2	2.4	9.4	19	2.5	2.0	7.4	13	2.2	1.9	6.4	10	1.9	1.8	5.8	8
	H	2.4	1.6	7.2	12	2.0	1.5	6.0	9	1.8	1.4	5.2	7	1.5	1.4	4.5	6
	L	1.8	1.1	5.4	8	1.5	1.0	4.6	6	1.3	0.9	4.1	6	1.1	0.9	3.5	4

Air temperature (°CDB - °CWB)		25-18															
Water temperature (Entering °C - Leaving °C)		6-11				7-12				8-13				9-14			
Model	Air flow	Total cooling capacity (kW)	Sensible cooling capacity (kW)	Water flow (l/min)	Water pressure drop (kPa)	Total cooling capacity (kW)	Sensible cooling capacity (kW)	Water flow (l/min)	Water pressure drop (kPa)	Total cooling capacity (kW)	Sensible cooling capacity (kW)	Water flow (l/min)	Water pressure drop (kPa)	Total cooling capacity (kW)	Sensible cooling capacity (kW)	Water flow (l/min)	Water pressure drop (kPa)
FWF02BF	HH	1.8	1.3	5.7	6	1.5	1.2	4.8	4	1.3	1.1	4.2	4	1.3	1.0	4.1	3
	H	1.6	1.2	4.7	4	1.4	1.1	4.1	3	1.3	1.0	3.9	3	1.1	0.9	3.9	3
	L	1.3	1.0	4.1	3	1.2	1.0	4.0	3	1.1	0.9	4.1	3	0.9	0.8	3.9	3
FWF03BF	HH	2.5	1.5	7.4	13	2.3	1.5	6.9	11	2.1	1.3	6.1	9	1.7	1.2	5.1	7
	H	2.2	1.2	6.4	10	2.0	1.1	5.8	8	1.8	1.0	5.2	7	1.5	0.9	4.3	5
	L	1.7	0.9	5.0	7	1.5	0.8	4.6	6	1.3	0.8	4.1	5	1.2	0.7	4.1	5
FWF04BF	HH	3.3	2.2	9.6	20	3.0	2.1	8.8	17	2.6	1.9	7.8	14	2.2	1.7	6.4	10
	H	2.6	1.5	7.6	13	2.4	1.4	7.0	12	2.1	1.3	6.2	9	1.8	1.2	5.2	7
	L	1.7	0.9	5.0	7	1.5	0.8	4.6	6	1.3	0.8	4.1	5	1.2	0.7	4.1	5
FWF05BF	HH	4.3	3.1	12.6	32	3.8	2.9	11.2	26	3.5	2.6	10.1	22	2.8	2.2	8.1	15
	H	3.3	2.1	9.6	20	3.0	2.0	8.8	17	2.7	1.8	7.8	14	2.2	1.6	6.3	10
	L	2.5	1.4	7.2	12	2.2	1.3	6.6	10	2.0	1.2	5.8	8	1.7	1.1	5.0	7

**NOTES**

1.  The capacity is only guaranteed at the nominal conditions

3TW33082-2

Air temperature (°CDB - °CWB)		27-19															
Water temperature (Entering °C - Leaving °C)		6-11				7-12				8-13				9-14			
Model	Air flow	Total cooling capacity (kW)	Sensible cooling capacity (kW)	Water flow (l/min)	Water pressure drop (kPa)	Total cooling capacity (kW)	Sensible cooling capacity (kW)	Water flow (l/min)	Water pressure drop (kPa)	Total cooling capacity (kW)	Sensible cooling capacity (kW)	Water flow (l/min)	Water pressure drop (kPa)	Total cooling capacity (kW)	Sensible cooling capacity (kW)	Water flow (l/min)	Water pressure drop (kPa)
FWF02BF	HH	2.2	1.5	6.4	7	2.0	1.5	5.7	6	1.7	1.4	5.3	5	1.6	1.2	4.7	4
	H	1.9	1.3	5.4	5	1.7	1.3	4.9	4	1.5	1.2	4.4	4	1.4	1.1	4.1	3
	L	1.5	1.1	4.4	4	1.4	1.1	4.1	3	1.2	1.0	3.7	3	1.2	0.9	3.4	3
FWF03BF	HH	2.9	1.8	8.5	16	2.7	1.7	7.7	13	2.4	1.6	7.2	12	2.2	1.4	6.4	10
	H	2.5	1.3	7.2	12	2.3	1.3	6.6	10	2.1	1.2	6.1	9	1.8	1.1	5.3	7
	L	2.0	1.0	5.7	8	1.8	1.0	5.2	7	1.6	0.9	4.8	6	1.4	0.8	4.1	5
FWF04BF	HH	3.8	2.5	11.1	25	3.5	2.4	10.0	21	3.2	2.2	9.3	19	2.8	2.0	8.1	15
	H	3.0	1.7	8.7	17	2.8	1.7	8.1	15	2.5	1.6	7.3	12	2.2	1.4	6.5	10
	L	2.0	1.0	5.7	8	1.8	1.0	5.2	7	1.6	0.9	4.8	6	1.4	0.8	4.1	5
FWF05BF	HH	4.9	3.4	14.2	40	4.5	3.3	12.8	33	4.0	3.1	11.8	28	3.6	2.8	10.5	23
	H	3.8	2.4	10.9	25	3.5	2.3	10	21	3.1	2.1	9.2	18	2.8	1.9	8.1	15
	L	2.8	1.5	8.2	15	2.6	1.5	7.5	13	2.3	1.4	6.8	11	2.1	1.3	6.2	9

Air temperature (°CDB - °CWB)		30-22															
Water temperature (Entering °C - Leaving °C)		6-11				7-12				8-13				9-14			
Model	Air flow	Total cooling capacity (kW)	Sensible cooling capacity (kW)	Water flow (l/min)	Water pressure drop (kPa)	Total cooling capacity (kW)	Sensible cooling capacity (kW)	Water flow (l/min)	Water pressure drop (kPa)	Total cooling capacity (kW)	Sensible cooling capacity (kW)	Water flow (l/min)	Water pressure drop (kPa)	Total cooling capacity (kW)	Sensible cooling capacity (kW)	Water flow (l/min)	Water pressure drop (kPa)
FWF02BF	HH	3.0	1.8	9.0	12	2.8	1.7	8.5	11	2.6	1.6	7.8	9	2.3	1.5	7.1	8
	H	2.6	1.6	7.8	9	2.5	1.5	7.2	8	2.3	1.4	6.7	7	2.1	1.3	6.0	6
	L	2.1	1.3	6.3	7	2.0	1.3	5.8	6	1.8	1.2	5.4	5	1.7	1.1	5.0	5
FWF03BF	HH	4.1	2.1	12.0	29	3.8	2.0	11.2	26	3.6	1.9	10.5	23	3.3	1.8	9.7	20
	H	3.5	1.6	10.1	22	3.2	1.5	9.4	19	3.0	1.4	8.8	17	2.8	1.3	8.2	15
	L	2.7	1.2	7.8	14	2.5	1.1	7.4	13	2.4	1.1	6.9	11	2.2	1.0	6.4	10
FWF04BF	HH	5.4	2.9	15.5	46	5.0	2.8	14.6	42	4.7	2.7	13.6	37	4.3	2.5	12.6	32
	H	4.2	2.0	12.2	30	4.0	2.0	11.5	27	3.7	1.9	10.7	24	3.4	1.8	10.0	21
	L	2.7	1.2	7.8	14	2.5	1.1	7.4	13	2.4	1.1	6.9	11	2.2	1.0	6.4	10
FWF05BF	HH	6.9	4.0	20.0	74	6.5	3.9	19.0	68	6.1	3.7	17.6	59	5.6	3.5	16.3	51
	H	5.4	2.8	15.6	47	5.0	2.7	14.6	42	4.7	2.5	13.6	37	4.3	2.4	12.6	32
	L	3.9	1.8	11.2	26	3.6	1.7	10.5	23	3.4	1.6	9.9	21	3.2	1.5	9.3	19

**NOTES**

1.  The capacity is only guaranteed at the nominal conditions

3TW33082-2

# 6 Capacity tables

## 6 - 2 Heating Capacity Tables

FWF-BF										
Air temperature (°CDB - °CWB)		20								
Water temperature (Entering °C - Leaving °C)		50-45			60-50			70-60		
Model	Airflow	Heating capacity (kW)	Water flow (l/min)	Water pressure drop (kPa)	Heating capacity (kW)	Water flow (l/min)	Water pressure drop (kPa)	Heating capacity (kW)	Water flow (l/min)	Water pressure drop (kPa)
FWF02BF	HH	2.3	6.8	15	2.9	4.2	7	3.9	6.0	12
	H	1.9	5.5	11	2.3	3.4	5	3.1	4.5	8
	L	1.4	4.1	7	1.7	2.6	4	2.3	3.3	5
FWF03BF	HH	2.3	6.8	9	2.8	4.2	4	3.8	5.4	6
	H	2.0	5.9	7	2.5	3.6	3	3.3	4.7	5
	L	1.7	5.0	5	2.1	3.2	3	2.8	4.0	4
FWF04BF	HH	2.9	8.5	13	3.6	5.2	5	4.9	7.7	11
	H	2.4	7.0	9	2.9	4.3	4	3.9	5.6	6
	L	1.7	5.0	5	2.1	3.2	3	2.8	4.0	4
FWF05BF	HH	3.7	10.8	20	4.5	6.6	8	6.1	8.7	13
	H	2.9	8.5	13	3.6	5.2	5	4.8	6.9	9
	L	2.1	6.2	7	2.6	3.8	3	3.5	5.0	5

FWF-BF										
Air temperature (°CDB - °CWB)		22								
Water temperature (Entering °C - Leaving °C)		50-45			60-50			70-60		
Model	Airflow	Heating capacity (kW)	Water flow (l/min)	Water pressure drop (kPa)	Heating capacity (kW)	Water flow (l/min)	Water pressure drop (kPa)	Heating capacity (kW)	Water flow (l/min)	Water pressure drop (kPa)
FWF02BF	HH	2.2	6.4	14	2.7	3.9	6	3.6	5.2	10
	H	1.7	5.1	10	2.1	3.1	5	2.9	4.2	7
	L	1.3	3.8	6	1.6	2.4	3	2.1	3.1	5
FWF03BF	HH	2.1	6.3	8	2.7	3.9	3	3.6	5.2	5
	H	1.9	5.5	6	2.3	3.4	3	3.1	4.5	4
	L	1.6	4.6	4	2.2	3.2	3	2.6	3.8	3
FWF04BF	HH	2.7	8.0	11	3.3	4.9	5	4.5	6.5	8
	H	2.2	6.4	8	2.7	3.9	3	3.7	5.3	6
	L	1.6	4.6	4	2.6	3.2	3	2.6	3.8	3
FWF05BF	HH	3.5	10.2	18	4.2	6.0	7	5.7	8.3	12
	H	2.7	8.0	11	3.3	4.8	5	4.5	6.6	8
	L	2.0	5.8	7	2.4	3.6	3	3.3	4.7	5

3TW33082-1

# 7 Dimensional drawings

## 7 - 1 Dimensional Drawings

2  
7

FWF-BT/BF

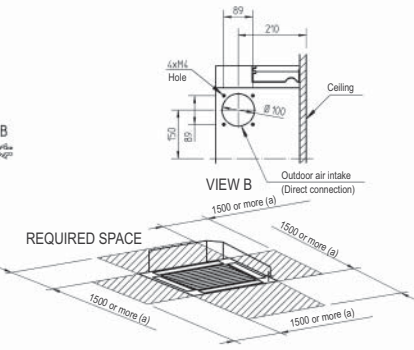
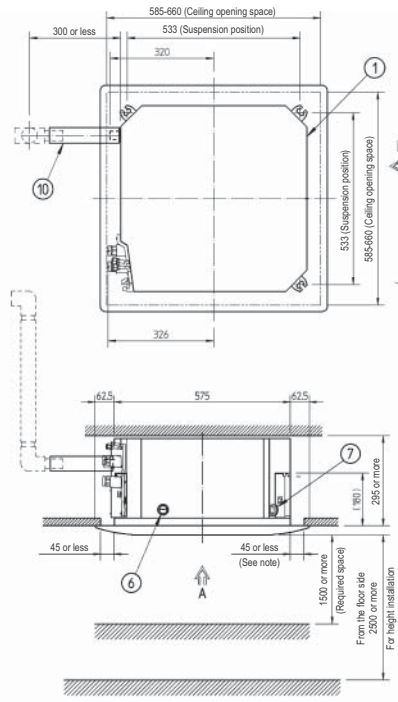
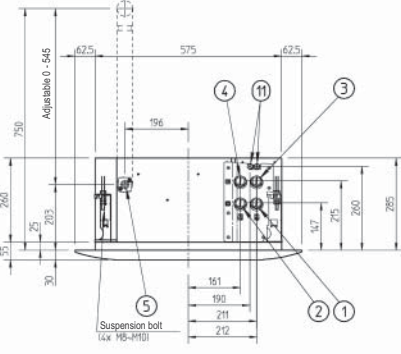
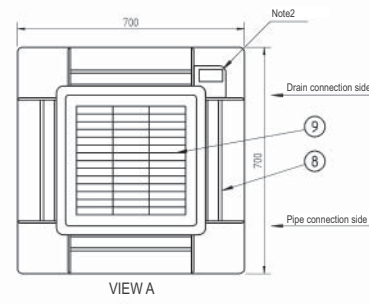

(a) When the discharge grille is covered (by an option kit) the required space is 200mm or more

Nr	Part name	Remark
1	Water pipe connection cooling in	3/4" BSP female (For FWF_B7T: water in)
2	Water pipe connection cooling out	3/4" BSP female (For FWF_B7T: water out)
3	Water pipe connection heating in	3/4" BSP female (For FWF-B7F)
4	Water pipe connection heating out	3/4" BSP female (For FWF-B7F)
5	Drain pipe connection	VP20 (O.D. Ø26)
6	Power supply entry hole	.
7	Transmission wiring entry hole	.
8	Air discharge grille	.
9	Suction grille	.
10	Drain hose (accessory)	I.D.Ø25 (Outlet)
11	Air purge	(1 for FWF_B7T, 2 for FWF_B7F)

DECORATION PANEL  
BYFQ60B White RAL 9010

3TW33044-1

**NOTES**

1. Sticking location for manufacturer's label: For indoor unit: on the bell mouth inside suction grille. For decoration panel: on the inner frame inside suction grille.
2. In case of using Infrared remote control, this position will be a signal receiver. Refer to drawing of Infrared remote control for details.
3. When the temperature and humidity in the ceiling exceeds 30°C and RH 80% or the fresh air is inducted into the ceiling or the unit continues 24 hours operation, an additional insulation is required. (Thickness 10mm or more of glaswool or PE foam)
4. Though the installation is acceptable up to maximum of 660 mm square ceiling opening, keep a clearance of 45 mm or less between the main unit and the ceiling opening, so that the panel overlap can be ensured.

# 7 Dimensional drawings

## 7 - 2 Dimensional Drawings with Accessories

FWF-BT-BF

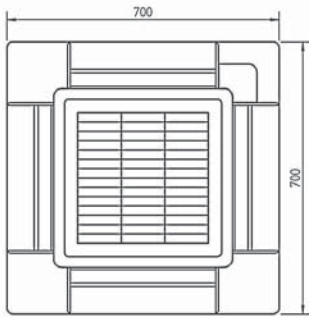

VIEW A

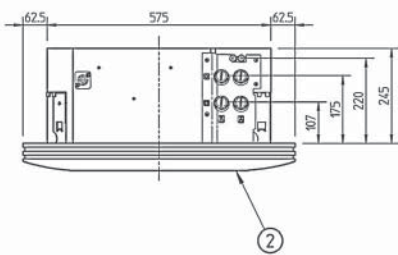
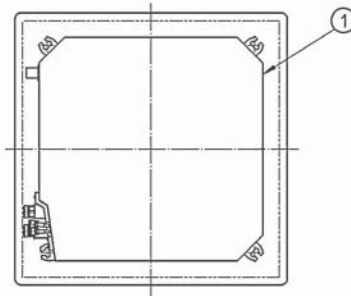

2

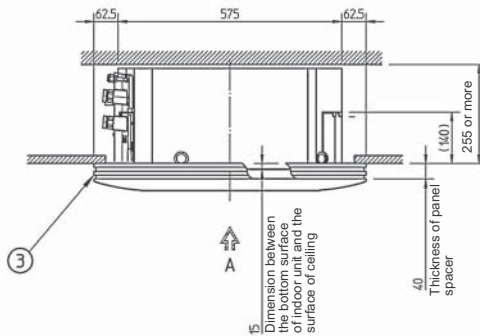

3

Dimension between the location of indoor unit and the surface of ceiling

Thickness of panel spacer

ITEM	PART NAME	REMARK
1	Indoor unit	-
2	Decoration panel	-
3	Panel spacer	-

**NOTE**

1. Number of pipe connections and air purges is depending on model type.

3TW33044-2

## 8 Centre of gravity

### 8 - 1 Centre of Gravity

FWF-BT/BF

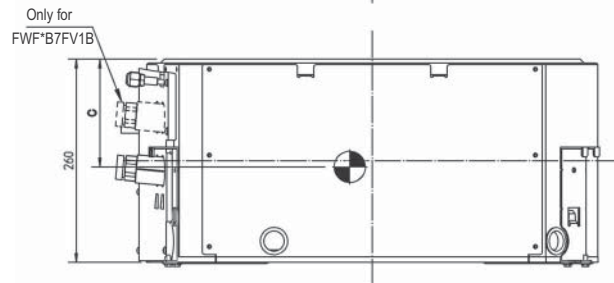
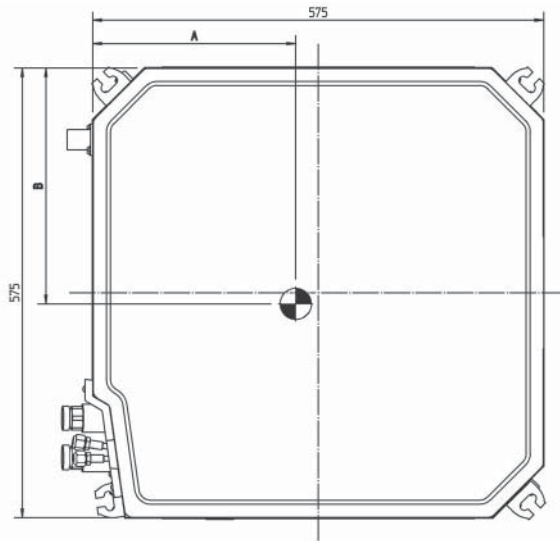

Model	A	B	C
FWF02B7TV1B	259	295	133
FWF02B7FV1B	256	300	132
FWF03-05B7TV1B	267	301	130
FWF03-05B7FV1B	257	312	135

4TW33044-3

# 9 Piping diagrams

## 9 - 1 Piping Diagrams

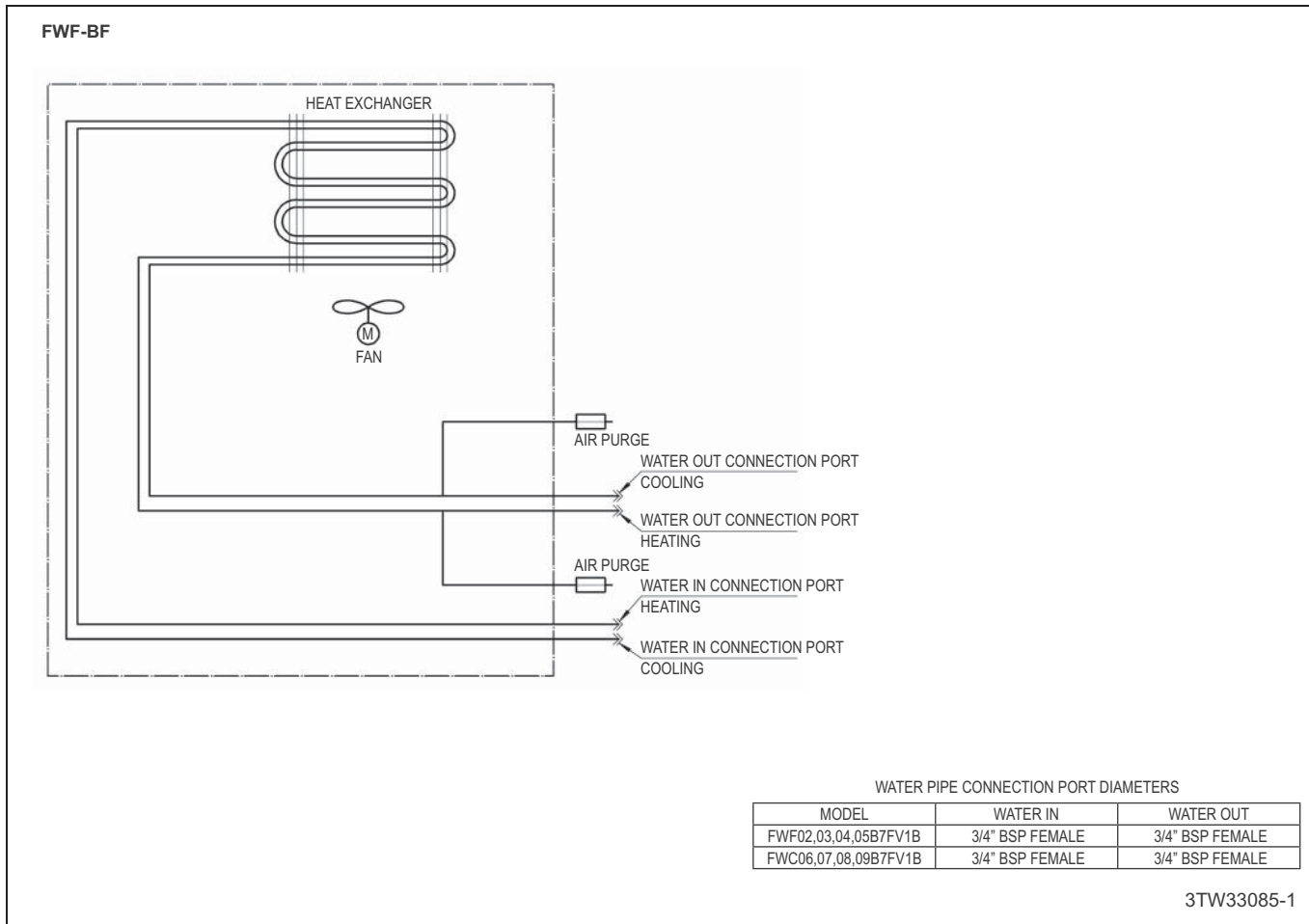

# 10 Sound data

## 10 - 1 Sound Power Spectrum

2  
10

FWF02-03BT, FWF02BF

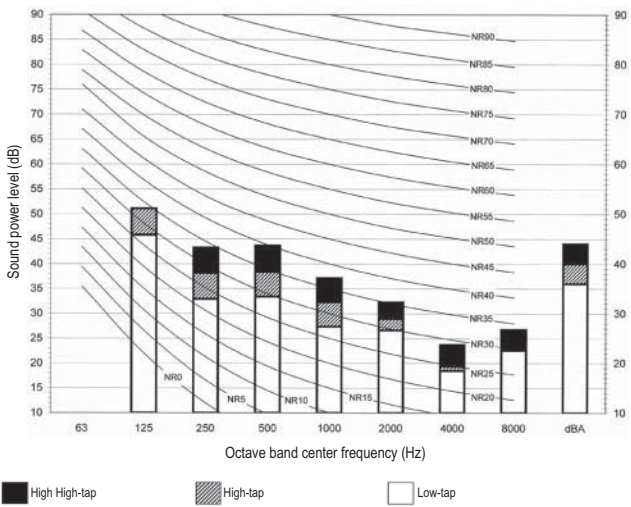

3TW33047-1A

**NOTES**

1. dBA = A-weighted sound pressure level. (A-scale according to IEC)
2. Reference acoustic pressures 0dB = 10E-6μW/m<sup>2</sup>
3. Measured according to ISO 3744

FWF03BF

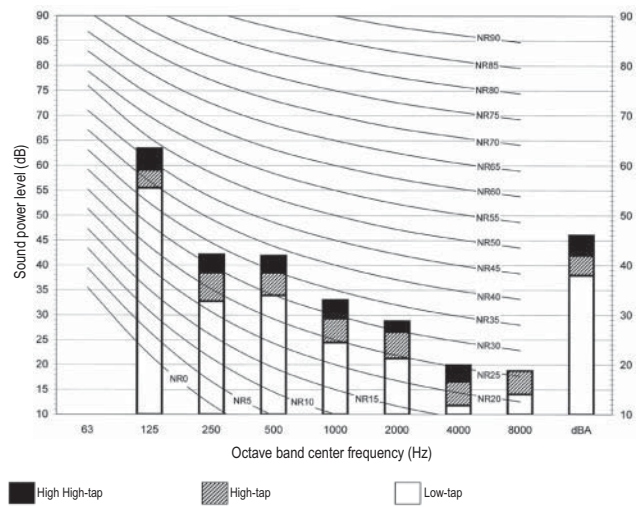

3TW33097-1A

**NOTES**

1. dBA = A-weighted sound pressure level. (A-scale according to IEC)
2. Reference acoustic pressures 0dB = 10E-6μW/m<sup>2</sup>
3. Measured according to ISO 3744

FWF04BF

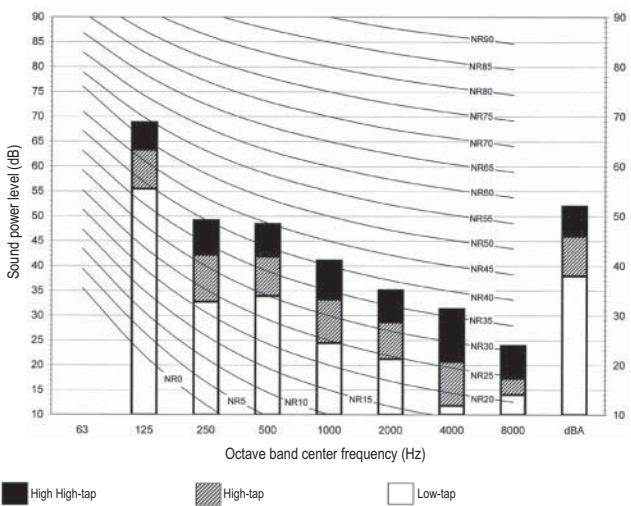

3TW33107-1A

**NOTES**

1. dBA = A-weighted sound pressure level. (A-scale according to IEC)
2. Reference acoustic pressures 0dB = 10E-6μW/m<sup>2</sup>
3. Measured according to ISO 3744

FWF05BF

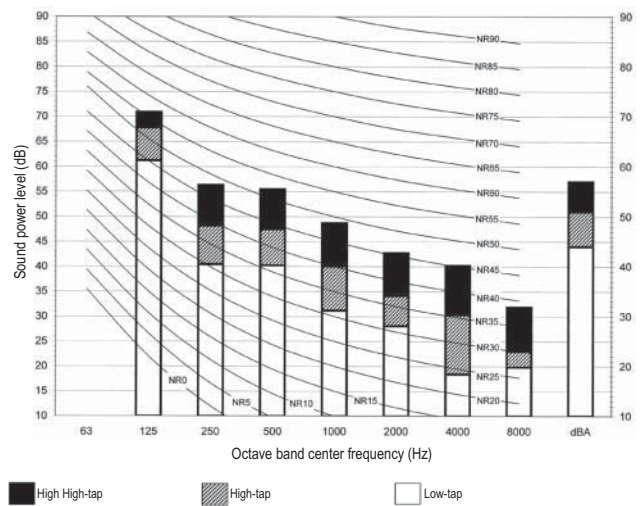

3TW33117-1A

**NOTES**

1. dBA = A-weighted sound pressure level. (A-scale according to IEC)
2. Reference acoustic pressures 0dB = 10E-6μW/m<sup>2</sup>
3. Measured according to ISO 3744

# 10 Sound data

## 10 - 2 Sound Pressure Spectrum

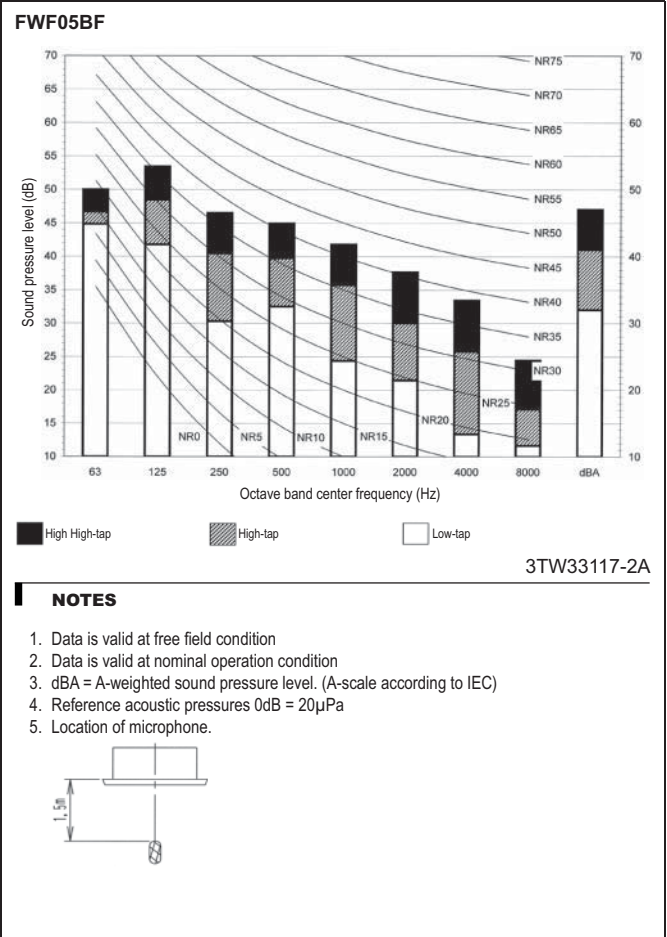
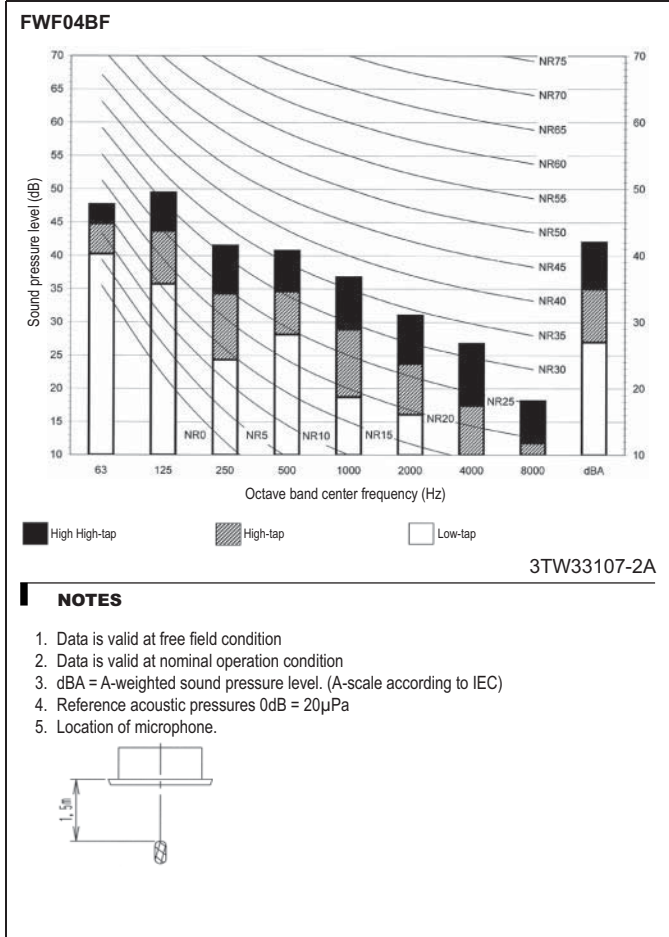
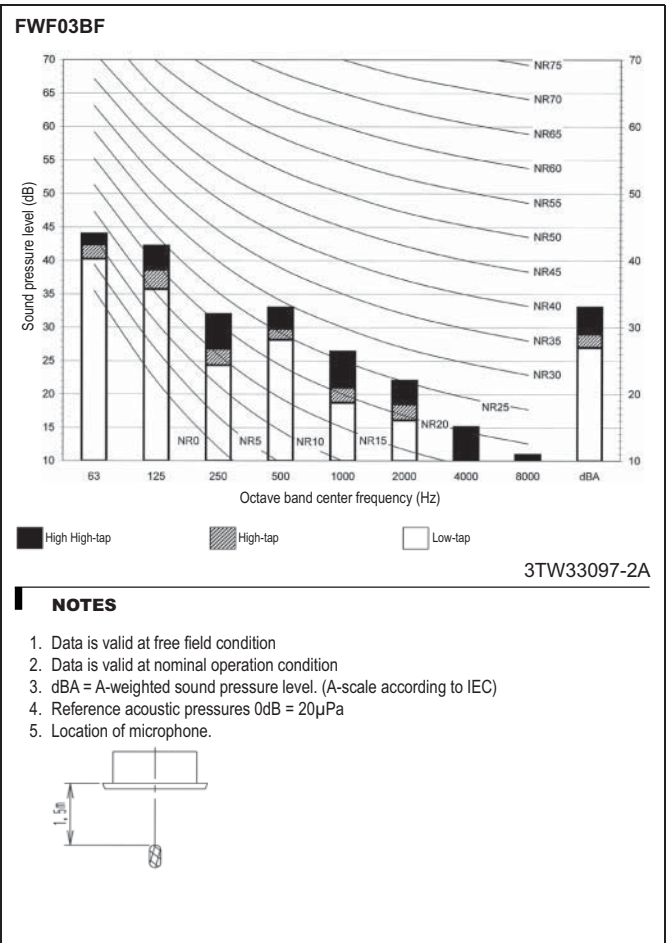
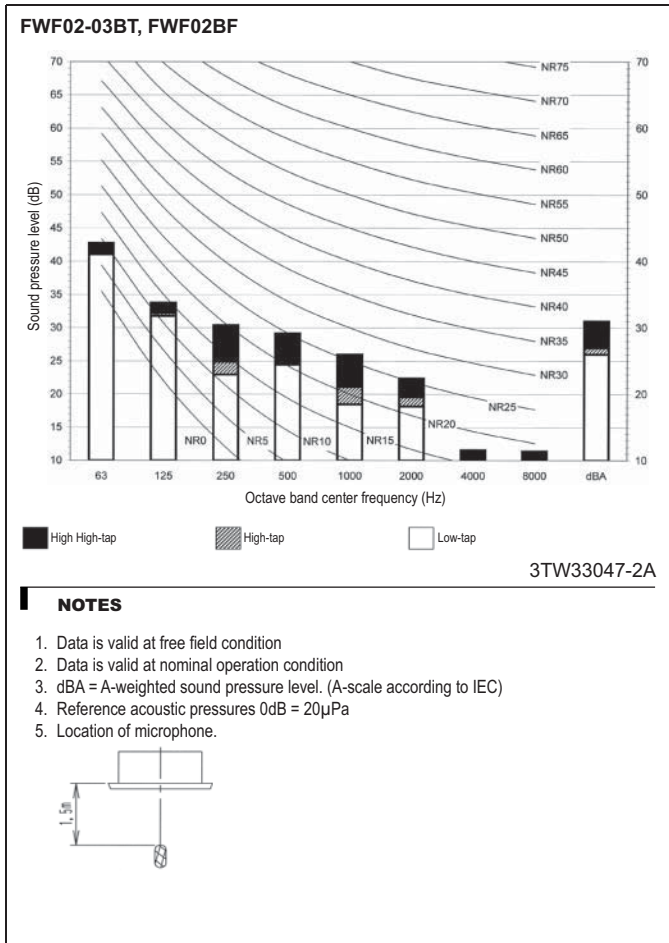

# 11 Hydraulic performance

## 11 - 1 Water Pressure Drop Curve Evaporator

2  
11

FWF-BF

Pressure drop over FWF02B7FV1B

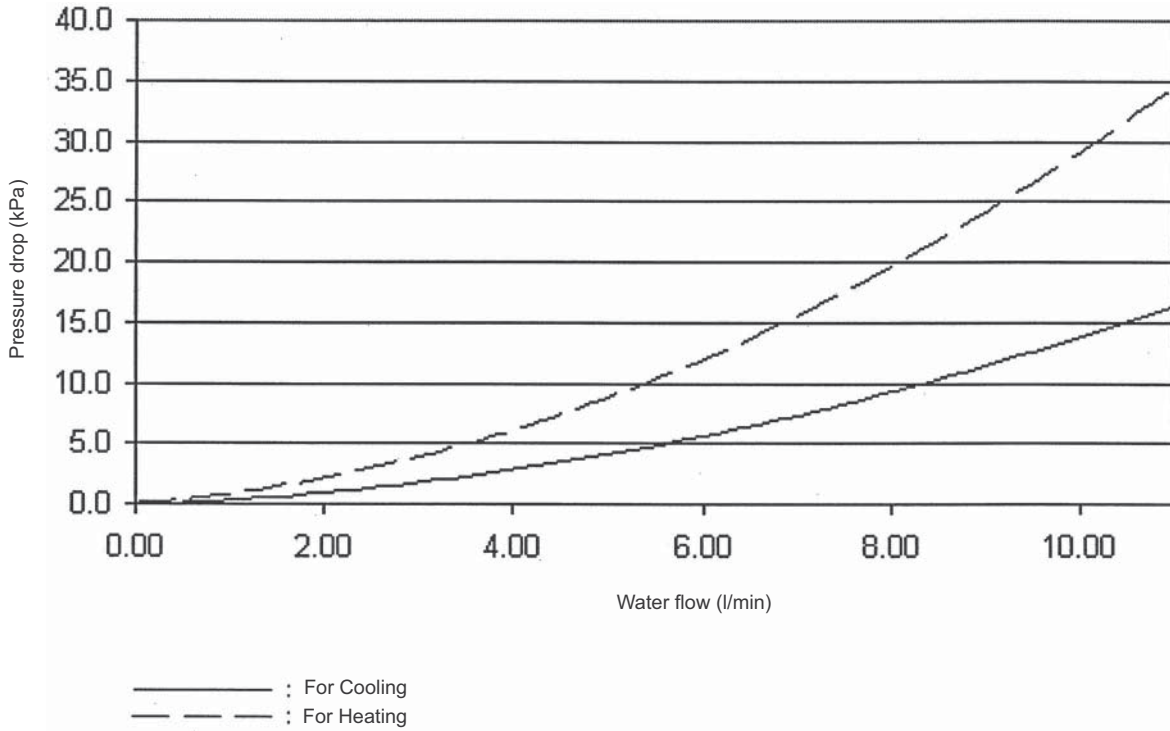

4TW33089-5

**NOTE**

1. This graph can be used to calculate the pressure drop over the fan coil unit. The pressure drop over the valve is not included.

FWF-BF

Pressure drop over FWF03-05B7FV1B

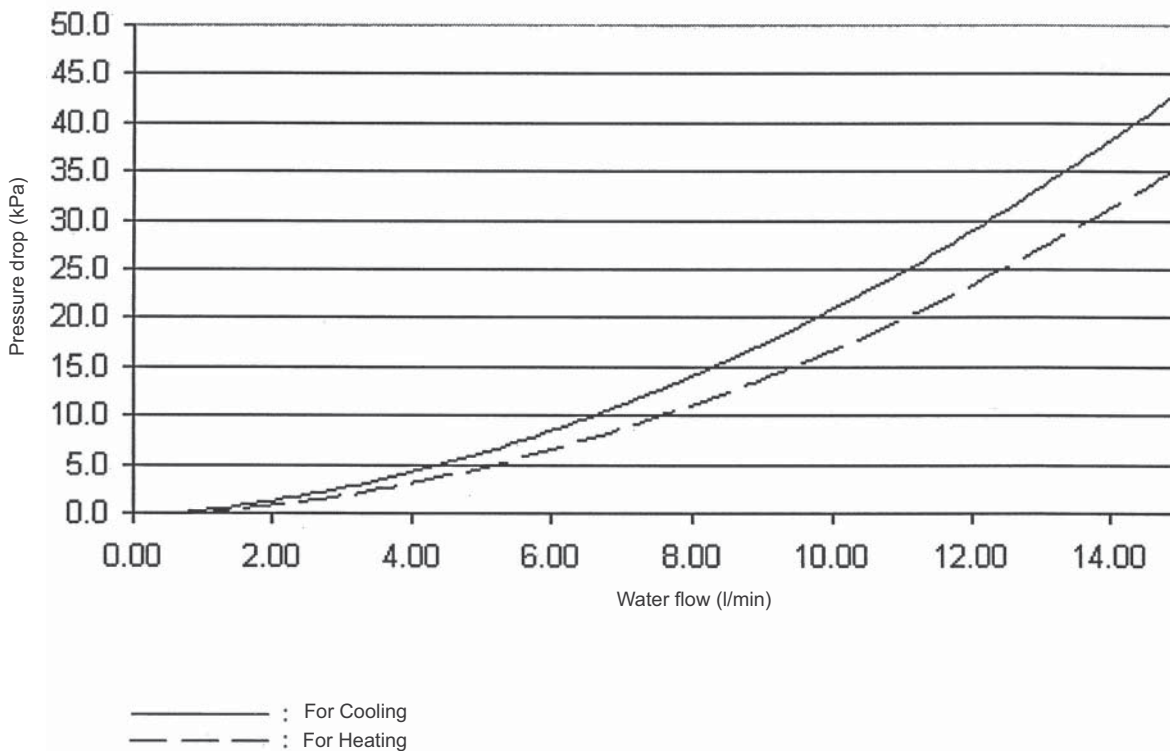

4TW33099-5

**NOTE**

1. This graph can be used to calculate the pressure drop over the fan coil unit. The pressure drop over the valve is not included.