

# Daikin Altherma low temperature split Technical Data

EHVH-E6V /  
EHVH-E9W /  
EHVX-E3V /  
EHVX-E6V /  
EHVX-E9W





# TABLE OF CONTENTS

## EHVH-E6V / EHVH-E9W / EHVX-E3V / EHVX-E6V / EHVX-E9W

---

1	<b>Features</b>	4
	EHVX-E6V, EHVX-E9W, EHVH-E9W, EHVH-E6V, EHVX-E3V	4
2	<b>Specifications</b>	5
3	<b>Electrical data</b>	16
4	<b>Combination table</b>	17
5	<b>Dimensional drawings</b>	18
6	<b>Centre of gravity</b>	19
7	<b>Piping diagrams</b>	20
8	<b>Wiring diagrams</b>	21
	Notes & Legend	21
	Control Circuit	22
	Power Supply, Back-up Heater	25
9	<b>External connection diagrams</b>	26
10	<b>Installation</b>	27
	Installation Method	27
11	<b>Operation range</b>	28
12	<b>Hydraulic performance</b>	30
	Static Pressure Drop Unit	30

# 1 Features

EHVX-E6V, EHVX-E9W, EHVH-E9W, EHVH-E6V, EHVX-E3V

Floor standing air to water heat pump for heating, cooling and hot water; ideal for low energy houses

1

- › A combined stainless steel domestic hot water tank of 180 or 230L and heat pump for easy installation
- › W-LAN Adapter connection
- › PCB board and hydraulic components are located in the front for easy access
- › Small installation footprint, similar to other household appliances
- › Integrated back-up heater choice of 3, 6, 9 kW as well as back-up heater less models are available



Onecta app  
(optional)



Online  
controller

## 2 Specifications

Technical specifications				EHVH04S18E6V	EHVH04S23E6V	EHVH08S18E6V	EHVH08S23E6V	
Heater capacity	Step 1	kW					2	
	Step 2	kW					2 or 4	
Power input	Nom.	kW					0.09	
Efficiency	Domestic Net calorific value hot water	%	118	135	118	135		
Casing	Colour	White + Black						
	Material	Precoated sheet metal						
Dimensions	Unit	Height	mm	1,650	1,850	1,650	1,850	
		Width	mm	595				
		Depth	mm	625				
	Packed unit	Height	mm	1,820	2,020	1,820	2,020	
		Width	mm	720				
		Depth	mm	740				
Weight	Unit	kg	119	128	119	128		
	Packed unit	kg	135	144	135	144		
Packing	Material	Wood / Carton / PE wrapping foil / Metal						
	Weight	kg	16					
PED	Category	Art4.3 / See note 9						
	Most critical part	Name P <sub>5</sub> *V Bar* <sup>l</sup>	Plate heat exchanger 38					
	Refrigerant side heat exchanger	Type	Plate heat exchanger					
Pump	Quantity	1						
	Plates	Quantity	42					
Water side Heat exchanger	Type	Plate heat exchanger						
	Quantity	1						
	Plates	Quantity	42					
Expansion vessel	Water volume	l	0.95					
	Water flow rate	Min. l/min	12.0 (1)					
	Volume	l	10					
Water filter	Max. water pressure	bar	3					
	Pre pressure	bar	1					
	Diameter perforations	mm	0.8					
Tank	Material	Stainless steel / Plastic						
	Name	Stainless steel domestic hot water tank 180 l		Stainless steel domestic hot water tank 230 L		Stainless steel domestic hot water tank 180 l		
Tank	Water volume	l	180	230	180	230		
	Material	Stainless steel (EN 1.4521)						
	Maximum water temperature	°C	70					
	Maximum water pressure	bar	10					
	Insulation	Material	Polyurethane foam					
		Heat loss	kWh/24h	12 (2)	1.4 (2)	12 (2)	1.4 (2)	
	Standing heat loss	S	W	50	58	50	58	
	Storage volume	V	l	181	220	181	220	
	Corrosion protection	Pickling						
	Energy efficiency class	B						
General	Supplier/ Manufacturer details	Name or trademark Name and address	Daikin Europe N.V. Daikin Europe N.V. - Zandvoordestraat 300, 8400 Oostende, Belgium					
	3-way valve	Coefficient of flow (kV)	Space heating	m <sup>3</sup> /h				8
Water circuit	Piping connections diameter	Domestic hot water tank	m <sup>3</sup> /h				10	
		Piping connections diameter	inch					
	Piping material	Cu						
	Internal piping diameter	inch						
	Piping	inch						
	Safety valve	bar						
	Manometer	Digital						
	Drain valve / fill valve	No						
	Shut off valve	Yes						
	Air purge valve	Yes						
	Total water volume	l	3.5 (3)					
	Minimum water volume in the system for cooling	l	10 (4)					
	Minimum water volume in the system for heating	l	0 (4)					

## 2 Specifications

2

Technical specifications				EHVH04S18E6V	EHVH04S23E6V	EHVH08S18E6V	EHVH08S23E6V
Water circuit - Domestic hot water side	Piping material			Stainless steel			
	Piping connections	Cold water in / Hot water out inch		G 3/4" FEMALE			
		Recirculation connection inch		G 3/4" FEMALE			
Refrigerant circuit	Gas side diameter		mm	15.9			
	Liquid side diameter		mm	6.40			
Sound power level	Nom.		dB(A)	42 (5)			
Sound pressure level	Nom.		dB(A)	28 (6)			
Operation range	Heating	Ambient	Min.	°C	0 (7)		
			Max.	°C	0 (7)		
	Water side	Ambient	Min.	°C	0 (7)		
			Max.	°C	0 (7)		
Operation range	Cooling	Ambient	Min.	°CDB	0 (7)		
			Max.	°CDB	0 (7)		
	Water side	Ambient	Min.	°C	0 (7)		
			Max.	°C	0 (7)		
	Domestic hot water side	Water	Min.	°C	0 (7)		
Max.			°C	0 (7)			
Safety devices	Item	01		Thermal cut out			

Electrical specifications				EHVH04S18E6V	EHVH04S23E6V	EHVH08S18E6V	EHVH08S23E6V
Power supply	Name			See note 10			
	Voltage range	Min.	%	10			
Max.		%	10				
IP class	IP			IP X0B			
Electric heater	Power supply	Name		6V3			
		Phase		1~ / 3~			
		Frequency		50			
		Voltage		230			
	Current	Maximum running current		A			
		Zmax	List	Ω			
Minimum Ssc value		Equipment complying with EN/IEC 61000-3-12					
Recommended fuses		A		20.000 (8)			
Wiring connections	Communication cable	Quantity	3				
		Remark	2.5 mm <sup>2</sup>				
	Electric meter	Quantity	2				
		Remark	Minimum 0.75 mm <sup>2</sup> (5VDC pulse detection)				
	Preferential kWh rate power supply	Quantity	Power: 2				
		Remark	Power 6.3A (Select diameter and type according to national and local regulations)				
	Domestic hot water pump	Quantity	2				
		Remark	Minimum 0.75 mm <sup>2</sup> (2A inrush, 1A continuous)				
	For power supply back-up heater	Quantity	Prewired				
		Remark					
	For connection with R6T	Quantity	2				
		Remark	Minimum 0.75 mm <sup>2</sup>				
	For connection with A3P	Quantity	Depends on thermostat type, cf. installation manual				
Remark		Voltage: 230V / Max. current: 100mA / Min. 0.75mm <sup>2</sup>					
For connection with M2S	Quantity	2					
	Remark	Voltage: 230V / Max. current: 100mA / Min. 0.75mm <sup>2</sup>					
For connection with optional	Quantity	4					
	Remark	100 mA, minimum 0.75 mm <sup>2</sup>					

(1) Operation area is extended to lower flow rates only in case the unit operates with heat pump only. (Not in startup, no BUH operation, no defrost operation). |

(2) Based on a dT of 45 K |

(3) Including piping + PHE + back-up heater; excluding expansion vessel |

(4) Excluding the water in the unit. This minimum water volume is sufficient for most applications. During critical processes extra water may be required. |

(5) DB/WB 7°C/6°C - LWC 35°C (DT=5°C) |

(6) Sound values are measured in a semi-anechoic room. Sound pressure level is a relative value, depending on the distance and acoustic environment. For more details, please refer to the sound level drawings. |

(7) Refer to operation range of the unit. |

(8) 4 pole 20 A curve 400V tripping class C (refer to wiring diagram) |

(9) PED unit category: Art353: excluded from scope of PED due to article 1, item 3.6 of 97/23/EC |

(10) Above mentioned power supply of the hydrobox is for the backup heater only. The switch box and the pump of the hydrobox are supplied via the outdoor unit. The optional domestic hot water tank has a separate power supply. |

(11) 2 pole 20 A curve 400V tripping class C (refer to wiring diagram)

## 2 Specifications

Technical specifications				EHVH08S18E9W		EHVH08S23E9W		
Heater capacity	Step 1		kW	3				
	Step 2		kW	max. 6 kW				
Power input	Nom.		kW	0.09				
Efficiency	Domestic Net calorific value		%	118		135		
Casing	Colour	White + Black						
	Material	Precoated sheet metal						
Dimensions	Unit	Height	mm	1,650		1,850		
		Width	mm		595			
		Depth	mm		625			
	Packed unit	Height	mm	1,820		2,020		
		Width	mm		720			
		Depth	mm		740			
Weight	Unit		kg	119		128		
	Packed unit		kg	135		144		
Packing	Material	Wood / Carton / PE wrapping foil / Metal						
	Weight		kg	16				
PED	Category	Art4.3 / See note 9						
	Most critical part	Name	Bar* <sup>l</sup>	Plate heat exchanger				
		P <sub>5</sub> *V		38				
Refrigerant side heat exchanger	Type	Plate heat exchanger						
	Quantity	1						
	Plates	Quantity	42					
Pump	Type	Glandless circulator						
	Nr of speeds	PWM						
	Power input		W	52				
Water side Heat exchanger	Type	Plate heat exchanger						
	Quantity	1						
	Plates	Quantity	42					
	Water volume		l	0.95				
	Water flow rate	Min.	l/min	12.0 (1)				
Expansion vessel	Volume		l	10				
	Max. water pressure		bar	3				
	Pre pressure		bar	1				
Water filter	Diameter perforations		mm	0.8				
	Material	Stainless steel / Plastic						
Tank	Name			Stainless steel domestic hot water tank 180 l	Stainless steel domestic hot water tank 230 L			
Tank	Water volume		l	180		230		
	Material	Stainless steel (EN 1.4521)						
	Maximum water temperature	70						
	Maximum water pressure	10						
	Insulation	Material	Polyurethane foam					
		Heat loss		kWh/24h	1.2 (2)		1.4 (2)	
	Standing heat loss	S	W	50		58		
	Storage volume	V	l	181		220		
	Corrosion protection	Pickling						
	Energy efficiency class	B						
General	Supplier/ Manufacturer details	Name or trademark	Daikin Europe N.V.					
		Name and address	Daikin Europe N.V. - Zandvoordestraat 300, 8400 Oostende, Belgium					
3-way valve	Coefficient of flow (kV)	Space heating	m <sup>3</sup> /h	8				
		Domestic hot water tank	m <sup>3</sup> /h	10				
Water circuit	Piping connections diameter		inch	G 1" (female)				
	Piping material	Cu						
	Internal piping diameter		inch	1"				
	Piping		inch	1"				
	Safety valve		bar	3				
	Manometer	Digital						
	Drain valve / fill valve	No						
	Shut off valve	Yes						
	Air purge valve	Yes						
	Total water volume		l	3.5 (3)				
	Minimum water volume in the system for cooling		l	10 (4)				
	Minimum water volume in the system for heating		l	0 (4)				

## 2 Specifications

Technical specifications				EHVH08S18E9W		EHVH08S23E9W		
Water circuit - Domestic hot water side	Piping material			Stainless steel				
	Piping connections	Cold water in / Hot water out	inch	G 3/4" FEMALE				
		Recirculation connection	inch	G 3/4" FEMALE				
Refrigerant circuit	Gas side diameter		mm	15.9				
	Liquid side diameter		mm	6.40				
Sound power level	Nom.			dBA				42 (5)
Sound pressure level	Nom.			dBA				28 (6)
Operation range	Heating	Ambient	Min.	°C	0 (7)			
			Max.	°C	0 (7)			
	Water side	Ambient	Min.	°C	0 (7)			
			Max.	°C	0 (7)			
Operation range	Cooling	Ambient	Min.	°CDB	0 (7)			
			Max.	°CDB	0 (7)			
	Water side	Ambient	Min.	°C	0 (7)			
			Max.	°C	0 (7)			
	Domestic hot water side	Water	Min.	°C	0 (7)			
			Max.	°C	0 (7)			
Safety devices	Item	01		Thermal cut out				

Electrical specifications				EHVH08S18E9W		EHVH08S23E9W		
Power supply	Name			See note 10				
	Voltage range	Min.	%	10				
Max.		%	10					
IP class	IP			IP X0B				
Electric heater	Power supply	Name			9W			
		Phase			3~			
		Frequency			50			
		Voltage			400			
	Current	Maximum running current			13.0			
		Zmax	List	Ω	0.22			
Recommended fuses			A				20.000 (8)	
Wiring connections	Communication cable	Quantity			3			
		Remark			2.5 mm <sup>2</sup>			
	Electric meter	Quantity			2			
		Remark			Minimum 0.75 mm <sup>2</sup> (5VDC pulse detection)			
	Preferential kWh rate power supply	Quantity			Power: 2			
		Remark			Power 6.3A (Select diameter and type according to national and local regulations)			
	Domestic hot water pump	Quantity			2			
		Remark			Minimum 0.75 mm <sup>2</sup> (2A inrush, 1A continuous)			
	For power supply back-up heater	Quantity			Prewired			
		Remark						
	For connection with R6T	Quantity			2			
		Remark			Minimum 0.75 mm <sup>2</sup>			
For connection with A3P	Quantity			Depends on thermostat type, cf. installation manual				
	Remark			Voltage: 230V / Max. current: 100mA / Min. 0.75mm <sup>2</sup>				
For connection with M2S	Quantity			2				
	Remark			Voltage: 230V / Max. current: 100mA / Min. 0.75mm <sup>2</sup>				
For connection with optional	Quantity			4				
	Remark			100 mA, minimum 0.75 mm <sup>2</sup>				

(1) Operation area is extended to lower flow rates only in case the unit operates with heat pump only. (Not in startup, no BUH operation, no defrost operation). |

(2) Based on a dT of 45 K |

(3) Including piping + PHE + back-up heater; excluding expansion vessel |

(4) Excluding the water in the unit. This minimum water volume is sufficient for most applications. During critical processes extra water may be required. |

(5) DB/WB 7°C/6°C - LWC 35°C (DT=5°C) |

(6) Sound values are measured in a semi-anechoic room. Sound pressure level is a relative value, depending on the distance and acoustic environment. For more details, please refer to the sound level drawings. |

(7) Refer to operation range of the unit. |

(8) 4 pole 20 A curve 400V tripping class C (refer to wiring diagram) |

(9) PED unit category: Art3S3: excluded from scope of PED due to article 1, item 3.6 of 97/23/EC |

(10) Above mentioned power supply of the hydrobox is for the backup heater only. The switch box and the pump of the hydrobox are supplied via the outdoor unit. The optional domestic hot water tank has a separate power supply. |

(11) 2 pole 20 A curve 400V tripping class C (refer to wiring diagram)

## 2 Specifications

Technical specifications				EHVX04S18E3V		EHVX04S23E3V		
Heater capacity	Step 1	kW				3		
Power input	Nom.	kW				0.09		
Efficiency	Domestic hot water	Net calorific value	%	118		135		
Casing	Colour	White + Black						
	Material	Precoated sheet metal						
Dimensions	Unit	Height	mm	1,650		1,850		
		Width	mm	595				
		Depth	mm	625				
	Packed unit	Height	mm	1,820		2,020		
		Width	mm	720				
		Depth	mm	740				
Weight	Unit	kg	119		128			
	Packed unit	kg	135		144			
Packing	Material	Wood / Carton / PE wrapping foil / Metal						
	Weight	kg	16					
PED	Category	Art4.3 / See note 9						
	Most critical part	Name	Plate heat exchanger					
	Ps*V	Bar*l	38					
Refrigerant side heat exchanger	Type	Plate heat exchanger						
	Quantity	1						
	Plates	Quantity	42					
Pump	Type	Glandless circulator						
	Nr of speeds	PWM						
	Power input	W	52					
Water side Heat exchanger	Type	Plate heat exchanger						
	Quantity	1						
	Plates	Quantity	42					
	Water volume	l	0.95					
	Water flow rate	Min.	l/min	12.0 (1)				
Expansion vessel	Volume	l	10					
	Max. water pressure	bar	3					
	Pre pressure	bar	1					
Water filter	Diameter perforations	mm	0.8					
	Material	Stainless steel / Plastic						
Tank	Name	Stainless steel domestic hot water tank 180 l		Stainless steel domestic hot water tank 230 L				
	Water volume	l	180		230			
Tank	Material	Stainless steel (EN 1.4521)						
	Maximum water temperature	°C	70					
	Maximum water pressure	bar	10					
	Insulation	Material	Polyurethane foam					
		Heat loss	kWh/24h	1.2 (2)		1.4 (2)		
	Standing heat loss	S	W	50		58		
	Storage volume	V	l	181		220		
	Corrosion protection	Pickling						
	Energy efficiency class	B						
	General	Supplier/ Manufacturer details	Name or trademark	Daikin Europe N.V.				
Name and address		Daikin Europe N.V. - Zandvoordestraat 300, 8400 Oostende, Belgium						
3-way valve	Coefficient of flow (kV)	Space heating	m <sup>3</sup> /h	8				
		Domestic hot water tank	m <sup>3</sup> /h	10				
Water circuit	Piping connections diameter	inch	G 1" (female)					
	Piping material	Cu						
	Internal piping diameter	inch	1"					
	Piping	inch	1"					
	Safety valve	bar	3					
	Manometer	Digital						
	Drain valve / fill valve	No						
	Shut off valve	Yes						
	Air purge valve	Yes						
	Total water volume	l	3.5 (3)					
	Minimum water volume in the system for cooling	l	10 (4)					
	Minimum water volume in the system for heating	l	0 (4)					

## 2 Specifications

Technical specifications				EHVX04S18E3V	EHVX04S23E3V
Water circuit - Domestic hot water side	Piping material			Stainless steel	
	Piping connections	Cold water in / Hot water out inch		G 3/4" FEMALE	
		Recirculation connection inch		G 3/4" FEMALE	
Refrigerant circuit	Gas side diameter	mm		15.9	
	Liquid side diameter	mm		6.40	
Sound power level	Nom.	dB(A)		42 (5)	
Sound pressure level	Nom.	dB(A)		28 (6)	
Operation range	Heating	Ambient Min.	°C	0 (7)	
		Max.	°C	0 (7)	
	Water side	Min.	°C	0 (7)	
		Max.	°C	0 (7)	
Operation range	Cooling	Ambient Min.	°CDB	0 (7)	
		Max.	°CDB	0 (7)	
	Water side	Min.	°C	0 (7)	
		Max.	°C	0 (7)	
Domestic hot water side	Min.	°C	0 (7)		
	Max.	°C	0 (7)		
Safety devices	Item	01		Thermal cut out	

Electrical specifications				EHVX04S18E3V	EHVX04S23E3V
Power supply	Name			See note 10	
	Voltage range	Min.	%	10	
Max.		%	10		
IP class	IP			IP X0B	
Electric heater	Power supply	Name		3V3	
		Phase		1~	
		Frequency	Hz	50	
		Voltage	V	230	
	Current	Maximum running current	A	13.0	
		Zmax List	Ω	0.22	
Recommended fuses		A	20.000 (8)		
Wiring connections	Communication cable	Quantity		3	
		Remark		2.5 mm <sup>2</sup>	
	Electric meter	Quantity		2	
		Remark		Minimum 0.75 mm <sup>2</sup> (5VDC pulse detection)	
	Preferential kWh rate power supply	Quantity		Power: 2	
		Remark		Power 6.3A (Select diameter and type according to national and local regulations)	
	Domestic hot water pump	Quantity		2	
		Remark		Minimum 0.75 mm <sup>2</sup> (2A inrush, 1A continuous)	
	For power supply back-up heater	Quantity		Prewired	
		Remark			
	For connection with R6T	Quantity		2	
Remark			Minimum 0.75 mm <sup>2</sup>		
For connection with A3P	Quantity		Depends on thermostat type, cf. installation manual		
	Remark		Voltage: 230V / Max. current: 100mA / Min. 0.75mm <sup>2</sup>		
For connection with M2S	Quantity		2		
	Remark		Voltage: 230V / Max. current: 100mA / Min. 0.75mm <sup>2</sup>		
For connection with optional	Quantity		4		
	Remark		100 mA, minimum 0.75 mm <sup>2</sup>		

(1) Operation area is extended to lower flow rates only in case the unit operates with heat pump only. (Not in startup, no BUH operation, no defrost operation). |

(2) Based on a dT of 45 K |

(3) Including piping + PHE + back-up heater; excluding expansion vessel |

(4) Excluding the water in the unit. This minimum water volume is sufficient for most applications. During critical processes extra water may be required. |

(5) DB/WB 7°C/6°C - LWC 35°C (DT=5°C) |

(6) Sound values are measured in a semi-anechoic room. Sound pressure level is a relative value, depending on the distance and acoustic environment. For more details, please refer to the sound level drawings. |

(7) Refer to operation range of the unit. |

(8) 2 pole 20 A curve 400V tripping class C (refer to wiring diagram) |

(9) PED unit category: Art3S3: excluded from scope of PED due to article 1, item 3.6 of 97/23/EC |

(10) Above mentioned power supply of the hydrobox is for the backup heater only. The switch box and the pump of the hydrobox are supplied via the outdoor unit. The optional domestic hot water tank has a separate power supply. |

(11) 4 pole 20 A curve 400V tripping class C (refer to wiring diagram)

## 2 Specifications

Technical specifications				EHVX04S18E6V	EHVX04S23E6V	EHVX08S18E6V	EHVX08S23E6V		
Heater capacity	Step 1	kW					2		
	Step 2	kW					2 or 4		
Power input	Nom.	kW					0.09		
Efficiency	Domestic Net calorific value hot water	%	118	135	118	135			
Casing	Colour	White + Black							
	Material	Precoated sheet metal							
Dimensions	Unit	Height	mm	1,650	1,850	1,650	1,850		
		Width	mm	595					
		Depth	mm	625					
	Packed unit	Height	mm	1,820	2,020	1,820	2,020		
		Width	mm	720					
		Depth	mm	740					
Weight	Unit	kg	119	128	119	128			
	Packed unit	kg	135	144	135	144			
Packing	Material	Wood / Carton / PE wrapping foil / Metal							
	Weight	kg	16						
PED	Category	Art4.3 / See note 9							
	Most critical part	Name P5*V Bar* <sup>l</sup>	Plate heat exchanger						
			38						
Refrigerant side heat exchanger	Type	Plate heat exchanger							
	Quantity	1							
	Plates	Quantity	42						
Pump	Type	Glandless circulator							
	Nr of speeds	PWM							
	Power input	W	52						
Water side Heat exchanger	Type	Plate heat exchanger							
	Quantity	1							
	Plates	Quantity	42						
	Water volume	l	0.95						
	Water flow rate	Min. l/min	12.0 (1)						
Expansion vessel	Volume	l	10						
	Max. water pressure	bar	3						
	Pre pressure	bar	1						
Water filter	Diameter perforations	mm	0.8						
	Material	Stainless steel / Plastic							
Tank	Name	Stainless steel domestic hot water tank 180 l		Stainless steel domestic hot water tank 230 L		Stainless steel domestic hot water tank 180 l		Stainless steel domestic hot water tank 230 L	
Tank	Water volume	l	180	230	180	230			
	Material	Stainless steel (EN 1.4521)							
	Maximum water temperature	°C	70						
	Maximum water pressure	bar	10						
	Insulation	Material	Polyurethane foam						
		Heat loss	kWh/24h	12 (2)	1.4 (2)	12 (2)	1.4 (2)		
	Standing heat loss	S	W	50	58	50	58		
	Storage volume	V	l	181	220	181	220		
	Corrosion protection	Pickling							
	Energy efficiency class	B							
General	Supplier/ Manufacturer details	Name or trademark Name and address	Daikin Europe N.V. Daikin Europe N.V. - Zandvoordestraat 300, 8400 Oostende, Belgium						
	3-way valve	Coefficient of flow (kV)	Space heating	m <sup>3</sup> /h				8	
			Domestic hot water tank	m <sup>3</sup> /h				10	
Water circuit	Piping connections diameter	inch	G 1" (female)						
	Piping material	Cu							
	Internal piping diameter	inch	1"						
	Piping	inch	1"						
	Safety valve	bar	3						
	Manometer	Digital							
	Drain valve / fill valve	No							
	Shut off valve	Yes							
	Air purge valve	Yes							
	Total water volume	l	3.5 (3)						
	Minimum water volume in the system for cooling	l	10 (4)						
	Minimum water volume in the system for heating	l	0 (4)						

## 2 Specifications

2

Technical specifications				EHVX04S18E6V	EHVX04S23E6V	EHVX08S18E6V	EHVX08S23E6V
Water circuit - Domestic hot water side	Piping material			Stainless steel			
	Piping connections	Cold water in / Hot water out inch		G 3/4" FEMALE			
		Recirculation connection inch		G 3/4" FEMALE			
Refrigerant circuit	Gas side diameter		mm	15.9			
	Liquid side diameter		mm	6.40			
Sound power level	Nom.		dB(A)	42 (5)			
Sound pressure level	Nom.		dB(A)	28 (6)			
Operation range	Heating	Ambient	Min.	°C	0 (7)		
			Max.	°C	0 (7)		
	Water side	Ambient	Min.	°C	0 (7)		
			Max.	°C	0 (7)		
Operation range	Cooling	Ambient	Min.	°CDB	0 (7)		
			Max.	°CDB	0 (7)		
	Water side	Ambient	Min.	°C	0 (7)		
			Max.	°C	0 (7)		
	Domestic hot water side	Water	Min.	°C	0 (7)		
Max.			°C	0 (7)			
Safety devices	Item	01		Thermal cut out			

Electrical specifications				EHVX04S18E6V	EHVX04S23E6V	EHVX08S18E6V	EHVX08S23E6V
Power supply	Name			See note 10			
	Voltage range	Min.	%	10			
Max.		%	10				
IP class	IP			IP X0B			
Electric heater	Power supply	Name		6V3			
		Phase		1~ / 3~			
		Frequency		50			
		Voltage		230			
	Current	Maximum running current		A			
		Zmax	List	Ω			
Minimum Ssc value		Equipment complying with EN/IEC 61000-3-12					
Recommended fuses		A		20.000 (8)			
Wiring connections	Communication cable	Quantity		3			
		Remark		2.5 mm <sup>2</sup>			
	Electric meter	Quantity		2			
		Remark		Minimum 0.75 mm <sup>2</sup> (5VDC pulse detection)			
	Preferential kWh rate power supply	Quantity		Power: 2			
		Remark		Power 6.3A (Select diameter and type according to national and local regulations)			
	Domestic hot water pump	Quantity		2			
		Remark		Minimum 0.75 mm <sup>2</sup> (2A inrush, 1A continuous)			
	For power supply back-up heater	Quantity		Prewired			
		For connection with R6T	Quantity		2		
	Remark		Minimum 0.75 mm <sup>2</sup>				
	For connection with A3P	Quantity		Depends on thermostat type, cf. installation manual			
		Remark		Voltage: 230V / Max. current: 100mA / Min. 0.75mm <sup>2</sup>			
For connection with M2S	Quantity		2				
	Remark		Voltage: 230V / Max. current: 100mA / Min. 0.75mm <sup>2</sup>				
For connection with optional	Quantity		4				
	Remark		100 mA, minimum 0.75 mm <sup>2</sup>				

(1) Operation area is extended to lower flow rates only in case the unit operates with heat pump only. (Not in startup, no BUH operation, no defrost operation). |

(2) Based on a dT of 45 K |

(3) Including piping + PHE + back-up heater; excluding expansion vessel |

(4) Excluding the water in the unit. This minimum water volume is sufficient for most applications. During critical processes extra water may be required. |

(5) DB/WB 7°C/6°C - LWC 35°C (DT=5°C) |

(6) Sound values are measured in a semi-anechoic room. Sound pressure level is a relative value, depending on the distance and acoustic environment. For more details, please refer to the sound level drawings. |

(7) Refer to operation range of the unit. |

(8) 4 pole 20 A curve 400V tripping class C (refer to wiring diagram) |

(9) PED unit category: Art353: excluded from scope of PED due to article 1, item 3.6 of 97/23/EC |

(10) Above mentioned power supply of the hydrobox is for the backup heater only. The switch box and the pump of the hydrobox are supplied via the outdoor unit. The optional domestic hot water tank has a separate power supply. |

(11) 2 pole 20 A curve 400V tripping class C (refer to wiring diagram)

## 2 Specifications

Technical specifications				EHVX08S18E9W		EHVX08S23E9W		
Heater capacity	Step 1		kW	3				
	Step 2		kW	max. 6 kW				
Power input	Nom.		kW	0.09				
Efficiency	Domestic Net calorific value		%	118		135		
Casing	Colour	White + Black						
	Material	Precoated sheet metal						
Dimensions	Unit	Height	mm	1,650		1,850		
		Width	mm		595			
		Depth	mm		625			
	Packed unit	Height	mm	1,820		2,020		
		Width	mm		720			
		Depth	mm		740			
Weight	Unit		kg	119		128		
	Packed unit		kg	135		144		
Packing	Material	Wood / Carton / PE wrapping foil / Metal						
PED	Weight		kg	16				
	Category	Art4.3 / See note 9						
	Most critical part	Name	Bar* <sup>l</sup>	Plate heat exchanger 38				
Refrigerant side heat exchanger	Type	Plate heat exchanger						
	Quantity	1						
Pump	Plates	Quantity		42				
	Type	Glandless circulator						
	Nr of speeds	PWM						
Water side Heat exchanger	Power input		W	52				
	Type	Plate heat exchanger						
	Quantity	1						
	Plates	Quantity		42				
	Water volume		l	0.95				
Expansion vessel	Water Min. flow rate		l/min	12.0 (1)				
	Volume		l	10				
	Max. water pressure		bar	3				
Water filter	Pre pressure		bar	1				
	Diameter perforations		mm	0.8				
Tank	Material	Stainless steel / Plastic						
	Name			Stainless steel domestic hot water tank 180 l		Stainless steel domestic hot water tank 230 L		
Tank	Water volume		l	180		230		
	Material	Stainless steel (EN 1.4521)						
	Maximum water temperature	70						
	Maximum water pressure	10						
	Insulation	Material	Polyurethane foam					
		Heat loss		kWh/24h	1.2 (2)		1.4 (2)	
	Standing S heat loss		W	50		58		
	Storage V volume		l	181		220		
	Corrosion protection	Pickling						
	Energy efficiency class	B						
General	Supplier/	Name or trademark		Daikin Europe N.V.				
	Manufacturer details	Name and address		Daikin Europe N.V. - Zandvoordestraat 300, 8400 Oostende, Belgium				
3-way valve	Coefficient of flow (kV)	Space heating	m <sup>3</sup> /h	8				
		Domestic hot water tank	m <sup>3</sup> /h	10				
Water circuit	Piping connections diameter		inch	G 1" (female)				
	Piping material	Cu						
	Internal piping diameter		inch	1"				
	Piping		inch	1"				
	Safety valve		bar	3				
	Manometer	Digital						
	Drain valve / fill valve	No						
	Shut off valve	Yes						
	Air purge valve	Yes						
	Total water volume		l	3.5 (3)				
	Minimum water volume in the system for cooling		l	10 (4)				
	Minimum water volume in the system for heating		l	0 (4)				

## 2 Specifications

Technical specifications				EHVX08S18E9W	EHVX08S23E9W
Water circuit - Domestic hot water side	Piping material			Stainless steel	
	Piping connections	Cold water in / Hot water out inch		G 3/4" FEMALE	
		Recirculation connection inch		G 3/4" FEMALE	
Refrigerant circuit	Gas side diameter	mm		15.9	
	Liquid side diameter	mm		6.40	
Sound power level	Nom.	dB(A)		42 (5)	
Sound pressure level	Nom.	dB(A)		28 (6)	
Operation range	Heating	Ambient	Min.	°C	0 (7)
			Max.	°C	0 (7)
	Water side	Ambient	Min.	°C	0 (7)
			Max.	°C	0 (7)
Operation range	Cooling	Ambient	Min.	°CDB	0 (7)
			Max.	°CDB	0 (7)
	Water side	Ambient	Min.	°C	0 (7)
			Max.	°C	0 (7)
	Domestic hot water side	Water	Min.	°C	0 (7)
			Max.	°C	0 (7)
Safety devices	Item	01		Thermal cut out	

Electrical specifications				EHVX08S18E9W	EHVX08S23E9W	
Power supply	Name			See note 10		
	Voltage range	Min.	%	10		
Max.		%	10			
IP class	IP			IP X0B		
Electric heater	Power supply	Name		9W		
		Phase		3~		
		Frequency		50		
		Voltage		400		
	Current	Maximum running current		13.0		
		Zmax	List	Ω		0.22
Recommended fuses		A		20.000 (8)		
Wiring connections	Communication cable	Quantity		3		
		Remark		2.5 mm <sup>2</sup>		
	Electric meter	Quantity		2		
		Remark		Minimum 0.75 mm <sup>2</sup> (5VDC pulse detection)		
	Preferential kWh rate power supply	Quantity		Power: 2		
		Remark		Power 6.3A (Select diameter and type according to national and local regulations)		
	Domestic hot water pump	Quantity		2		
		Remark		Minimum 0.75 mm <sup>2</sup> (2A inrush, 1A continuous)		
	For power supply back-up heater		Quantity		Prewired	
	For connection with R6T	Quantity		2		
		Remark		Minimum 0.75 mm <sup>2</sup>		
	For connection with A3P	Quantity		Depends on thermostat type, cf. installation manual		
Remark			Voltage: 230V / Max. current: 100mA / Min. 0.75mm <sup>2</sup>			
For connection with M2S	Quantity		2			
	Remark		Voltage: 230V / Max. current: 100mA / Min. 0.75mm <sup>2</sup>			
For connection with optional	Quantity		4			
	Remark		100 mA, minimum 0.75 mm <sup>2</sup>			

## 2 Specifications

- (1) Operation area is extended to lower flow rates only in case the unit operates with heat pump only. (Not in startup, no BUH operation, no defrost operation). |
- (2) Based on a  $\Delta T$  of 45 K |
- (3) Including piping + PHE + back-up heater; excluding expansion vessel |
- (4) Excluding the water in the unit. This minimum water volume is sufficient for most applications. During critical processes extra water may be required. |
- (5) DB/WB 7°C/6°C - LWC 35°C (DT=5°C) |
- (6) Sound values are measured in a semi-anechoic room. Sound pressure level is a relative value, depending on the distance and acoustic environment. For more details, please refer to the sound level drawings. |
- (7) Refer to operation range of the unit. |
- (8) 4 pole 20 A curve 400V tripping class C (refer to wiring diagram) |
- (9) PED unit category: Art3§3: excluded from scope of PED due to article 1, item 3.6 of 97/23/EC |
- (10) Above mentioned power supply of the hydrobox is for the backup heater only. The switch box and the pump of the hydrobox are supplied via the outdoor unit. The optional domestic hot water tank has a separate power supply. |
- (11) 2 pole 20 A curve 400V tripping class C (refer to wiring diagram)

# 3 Electrical data

## 3 - 1 Electrical Data

3

### EHV(H-X-Z)-E(3V\_6V\_9W)(G)

Electrical specifications													
Not applicable for -EHVH(04/08)D(A/J)- models.													
Type	kW	3V				6V				9W			
		3	2-4	2-6	4-6	-2-4 (in case of emergency: -2-6)	6	3-6	3-9	-3-6 (in case of emergency: -3-9)	2		
Capacity setting		1	2	2	2	2	2	1	2	2	2	2	
Capacity stage -1-	kW	3	2	2	2	2	2	6	3	3	3	3	
Capacity stage -2-	kW	-	4	6	4	4	4	-	6	9	6	9	
Minimum time delay between stages		Note -4-				Note -5-				Note -5-			
Power supply (1)	Phase	1~				3~				3~			
	Frequency	50				50				50			
Current (2)	Nominal running current	A	13	17,4	26,1	26,1	17,4	26,1	15	8,7	13	8,7	13
	Zmax (backup heater)	Ω	0,34	0,22	0,22	0,22	0,22	0,22	-	-	-	-	-
Minimum Ssc value		kVA	-	(3)	-	(3)	-	-	-	-	-	-	

Notes	(1) The above-mentioned power supply of the hydrobox is for the backup heater only. (2) Booster heater power supply In accordance with EN/IEC 61000-3-11, it may be necessary to consult the distribution network operator to ensure that the equipment is connected only to a supply with Zsys ≤ Zmax. (3) The equipment complies with EN/IEC 61000-3-12.											
	EN/IEC 61000-3-11 European/International Technical Standard setting the limits for voltage changes, voltage fluctuations and flicker in public low-voltage supply systems for equipment with rated current ≤ 75 A. EN/IEC 61000-3-12 European/International Technical Standard setting the limits for harmonic currents produced by equipment connected to public low-voltage systems with input current > 16 A and ≤ 75 A per phase. Zsys System impedance											

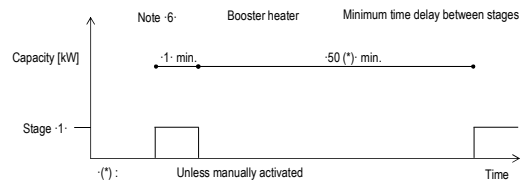
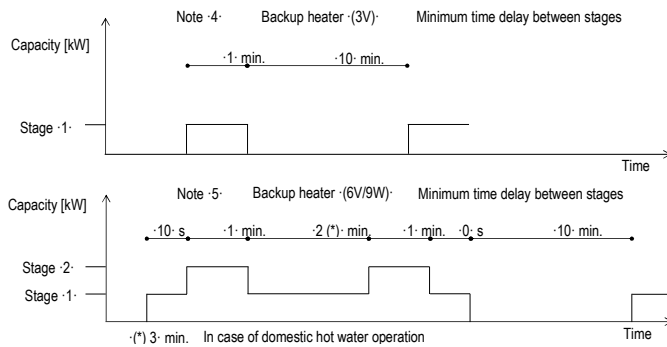

4D111982B

### EHBH-E6V / EHBH-E9W / EHBX-E6V / EHBX-E9W / EHVH-E6V / EHVH-E9W / EHVH-UE6V / EHVX-E3V / EHVX-E6V / EHVX-E9W / EHVZ-E6V / EHVZ-E9W

- \* Electrical meter specification
  - Pulse meter type/voltage-free contact for 5 V DC detection by PCB.
  - Possible number of pulses
    - 0.1· pulse/kWh
    - 1· pulse/kWh
    - 10· pulse/kWh
    - 100· pulse/kWh
    - 1000· pulse/kWh
  - Pulse duration
    - minimum On time: ·40ms·
    - Minimum OFF time: ·100ms·
  - Measurement type (depending on installation)
    - Single-phase AC meter
    - Three-phase AC meter
- Balanced loads
- Unbalanced loads

- \* Electrical meter installation guideline
  - It is the responsibility of the installer to cover the complete power consumption with electrical meters (combination of estimation metering is not allowed).
  - Required number of electrical meters

Outdoor unit type	ERGA(04/06/08)(D/E)AV3(H)(7)								ERLA03DAV3
Indoor unit type	*HB(H/X)(04/08)(D/E)A*				*HV(H/X)(04/08)(D/E)(A/J)*				EHF*03S18DJ3V
Backup heater type	6V		9W		3V		6V		3V
Backup heater power supply	1~230V	3~230V	3~400V	1~230V	1~230V	3~230V	3~400V	1~230V	1~230V
Backup heater configuration	2/4/6kW	6kW	3/6/9kW	3kW	2/4/6kW	6kW	3/6/9kW	3kW	3kW
Normal kWh rate power supply									
Electrical meter type	1~	1	-	-	1	1	-	-	1
	3~ balanced	-	-	-	-	-	-	-	-
	3~ unbalanced	-	1	1	-	-	1	1	-
Preferential kWh rate power supply									
Electrical meter type	1~	2	1	1	2	2	1	1	2
	3~ balanced	-	-	-	-	-	-	-	-
	3~ unbalanced	-	1	1	-	-	1	1	-

Immerision heater (no backup heater)		ERGA(04/06/08)(D/E)AV3(H)(7)		
Outdoor unit type	*HV(H/X)(04/08)D(A/J)V			
Indoor unit type	Booster heater (·2.4· kW)			
Backup heater type	1~			
Immerision heater power supply	230V			
Normal kWh rate power supply				
Electrical meter type	1~	1		
	3~ balanced	-		
	3~ unbalanced	-		
Unit preferential kWh rate power supply				
Electrical meter type	1~	2		
	3~ balanced	-		
	3~ unbalanced	-		

4D113240D

# 4 Combination table

## 4 - 1 Combination Table

### EHVH-E6V / EHVH-E9W / EHVH-UE6V / EHVX-E3V / EHVX-E6V / EHVX-E9W / EHVZ-E6V / EHVZ-E9W

Factory-mounted equipment for -EHV(H/X/Z)04S\*(E/A/J)\*-

Description	EHV(H/X/Z)04S*(E/A/J)*			
	18 - 3V	18 - 6V (9)	23 - 3V	23 - 6V (9)
Heating only model -EHVH*		18 - 6V (9)		23 - 6V (9)
Reversible model -EHVX*	18 - 3V	18 - 6V (9)	23 - 3V	23 - 6V (9)
(Integrated Bizzone)		18 - 6V (9)		
Heating only indoor unit for the UK		18 - 6V (9)		23 - 6V (9)
Backup heater -3kW 1N~230 V-	o	-	o	-
Backup heater -2-4-6kW 1N~230 V-	-	o	-	o
Backup heater -2-4-6kW 3~230 V-	-	o	-	o
Backup heater -3-6-9kW 3N~400 V-	-	-	-	-
Domestic hot water tank -180L	o	o	-	-
Domestic hot water tank -230L	-	-	o	o

Factory-mounted equipment for -EHV(H/X/Z)08S\*(E/A/J)\*-

Description	EHV(H/X/Z)08S*(E/A/J)*			
	18 - 6V (9)	18 - 9W (9)	23 - 6V (9)	23 - 9W (9)
Heating only model -EHVH*	18 - 6V (9)	18 - 9W (9)	23 - 6V (9)	23 - 9W (9)
Reversible model -EHVX*	18 - 6V (9)	18 - 9W (9)	23 - 6V (9)	23 - 9W (9)
(Integrated Bizzone)	18 - 6V (9)	18 - 9W (9)	23 - 6V (9)	23 - 9W (9)
Heating only indoor unit for the UK	18 - 6V (9)		23 - 6V (9)	
Backup heater -3kW 1N~230 V-	-	-	-	-
Backup heater -2-4-6kW 1N~230 V-	o	-	o	-
Backup heater -2-4-6kW 3~230 V-	o	-	o	-
Backup heater -3-6-9kW 3N~400 V-	-	o	-	o
Domestic hot water tank -180L	o	o	-	-
Domestic hot water tank -230L	-	-	o	o

Outdoor combination table for -EHV(H/X/Z)04/08S(U)18/23E(A/J)\*-

		ERGA04EAV3	ERGA06EAV3	ERGA08EAV3	ERGA04EAV3A	ERGA06EAV3A	ERGA08EAV3A
EHVH04S(18/23)E(A/J)*	Heating only indoor unit	o	---	---	o	---	---
EHVX04S(18/23)E(A/J)*	Reversible indoor unit	o	---	---	o	---	---
EHVZ04S(18/23)E(A/J)*	(Integrated Bizzone)	o	---	---	o	---	---
EHVH04SU(18/23)E(A/J)*	Heating only indoor unit for the UK	o	---	---	o	---	---
EHVH08S(18/23)E(A/J)*	Heating only indoor unit	---	o	o	---	o	o
EHVX08S(18/23)E(A/J)*	Reversible indoor unit	---	o	o	---	o	o
EHVZ08S(18/23)E(A/J)*	(Integrated Bizzone)	---	o	o	---	o	o
EHVH08SU(18/23)E(A/J)*	Heating only indoor unit for the UK	---	o	o	---	o	o

		ERGA04EAV37	ERGA04EAV3H	ERGA06EAV3H	ERGA08EAV3H	ERGA08EAV3H7
EHVH04S(18/23)E(A/J)*	Heating only indoor unit	o	o	---	---	---
EHVX04S(18/23)E(A/J)*	Reversible indoor unit	o	o	---	---	---
EHVZ04S(18/23)E(A/J)*	(Integrated Bizzone)	---	o	---	---	---
EHVH04SU(18/23)E(A/J)*	Heating only indoor unit for the UK	---	o	---	---	---
EHVH08S(18/23)E(A/J)*	Heating only indoor unit	---	---	o	o	o
EHVX08S(18/23)E(A/J)*	Reversible indoor unit	---	---	o	o	o
EHVZ08S(18/23)E(A/J)*	(Integrated Bizzone)	---	---	o	o	o
EHVH08SU(18/23)E(A/J)*	Heating only indoor unit for the UK	---	---	o	o	o

Kit availability

Reference	Description	EHV*(04/08S)*E(A/J)*						EHVH(04/08)SU*(E/A/J)*	
		18 - 3V	18 - 6V	18 - 9W	23 - 3V	23 - 6V	23 - 9W	18 - 6V	23 - 6V
EHVH*	Heating only indoor unit	---	18 - 6V	18 - 9W	---	23 - 6V	23 - 9W		
EHVX*	Reversible indoor unit	18 - 3V	18 - 6V	18 - 9W	23 - 3V	23 - 6V	23 - 9W		
EHVZ*	(Integrated Bizzone)	---	18 - 6V	18 - 9W	---	23 - 6V	23 - 9W		
EHVH*U*	Heating only indoor unit for the UK							18 - 6V	23 - 6V
EKRP1HBAA	Digital I/O PCB	*(1) (2)	o	o	o	o	o	o	o
EKRP1AHTA	Demand PCB	*(3)	o	o	o	o	o	o	o
EKPCAB4	PC cable	*(4)	o	o	o	o	o	o	o
KRCS01-1	Remote indoor sensor	*(5)	o	o	o	o	o	o	o
EKRSCA1	Remote sensor for outdoor	*(5)	o	o	o	o	o	o	o
EKHVTC	Corner pipe bend kit								
EKHVC0N4	Conversion kit: heating only to reversible.		o	o	o	o	o	o	o
EKUHWG3D	-G3- kit							o (6)	o (6)
BRP069A71	WLAN module	*(7)	o	o	o	o	o	o	o
BRC1HH*	HCI (Human Comfort Interface)		o	o	o	o	o	o	o
EKRELSG	Relay for Smart Grid								
FWXV10ATV3	Heat pump convector		o	o	o	o	o	o	o
FWXV15ATV3	Heat pump convector		o	o	o	o	o	o	o
FWXV20ATV3	Heat pump convector		o	o	o	o	o	o	o
EKRTWA	Wired room thermostat		o	o	o	o	o	o	o
EKRTR1	Wireless room thermostat		o	o	o	o	o	o	o
EKRTETS	External sensor room thermostat	*(8)	o	o	o	o	o	o	o

Reference	Description	EHVH*	EHVX*
	Only applicable for -EHVH* & EHVX*- models	EHVH*	EHVX*
BZKA7V3	Bizzone kit	o	o

Notes

- PCB that provides additional output connections:
  - Control external heat source (bivalent operation).
  - Output remote ON/OFF signal space heating/cooling OR bottom plate heater -\*KBPTH16\* - control.
  - Remote alarm output
- Additional relays to allow bivalent control in combination with an external room thermostat are field-supplied.
- PCB to receive up to 4 digital inputs for power limitation, only for -EHV(H/X/Z)04/08E(A/J)\*.
- Data cable for connection with PC.
- Only 1 remote sensor can be connected: indoor OR outdoor sensor.
- This kit is mandatory for the UK models.
- The WLAN cartridge is supplied in the accessory bag of the unit and is meant to be plugged into the SD card slot on the MMI-2. In case of bad signal reception, the WLAN cartridge can be removed and replaced by the WLAN module.
- Can only be used in combination with wireless room thermostat -EKTR1-.
- The backup heater capacity depends on a user interface setting.

Remark

Other combinations than mentioned in this combination table are prohibited.

3D130019A

# 5 Dimensional drawings

## 5 - 1 Dimensional Drawings

5

**EHVX-E3V**  
**EHV(H-X)-E6V**  
**EHV(H-X)-E9W**  
**EHVX-E6VG**

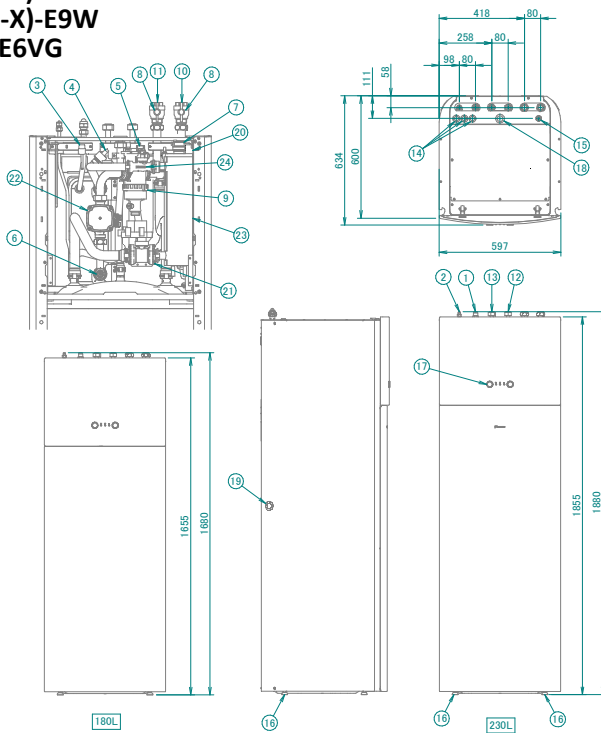

- ① Gas pipe connection ·Ø 15.90mm· flare
- ② Liquid pipe connection ·Ø 6.35mm· flare
- ③ Refrigerant pressure sensor
- ④ Space heating water pressure sensor
- ⑤ Safety valve
- ⑥ Drain valve water circuit
- ⑦ Air purge
- ⑧ Shut-off valve
- ⑨ Magnetic filter / dirt separator
- ⑩ Water in connection ·1" F BSP·
- ⑪ Water out connection ·1" F BSP·
- ⑫ Domestic hot water: cold water in ·3/4" F BSP·
- ⑬ Domestic hot water: hot water out ·3/4" F BSP·
- ⑭ High voltage wiring intake ·Ø 24mm·
- ⑮ Low voltage wiring intake ·Ø 15mm·
- ⑯ Levelling feet
- ⑰ User interface
- ⑱ Recirculation connection ·G 3/4"· (female)
- ⑲ Drain outlet (unit + safety valve)
- ⑳ Expansion vessel
- ㉑ 3-way valve
- ㉒ Pump
- ㉓ Backup heater
- ㉔ Flow sensor

Screws used in this unit:

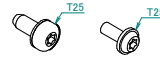

The typical field installation has to be done according to the applicable legislation.

For examples, refer to the installer reference guide.

**3D112072B**

# 6 Centre of gravity

## 6 - 1 Centre of Gravity

EHVX-E3V  
 EHV(H-X-Z)-E6V  
 EHV(H-X-Z)-E9W  
 EHVX-E6VG

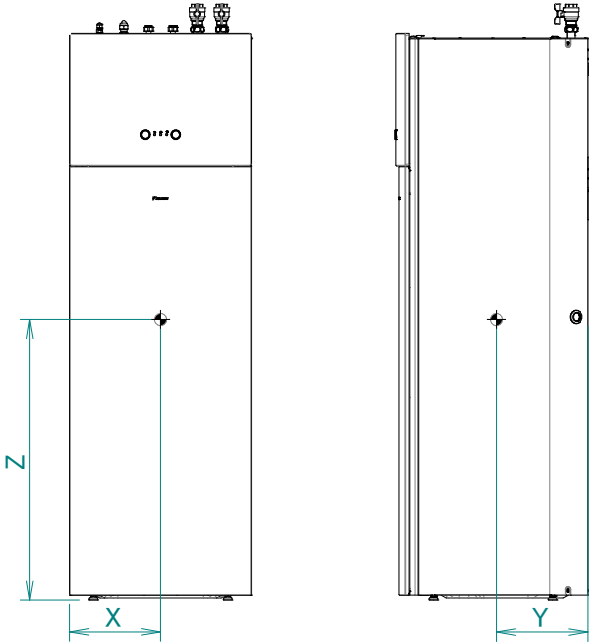

MODEL	X	Y	Z
180L	297.5	299	718
230L	297.5	299	858

**3D113623A**

# 7 Piping diagrams

## 7 - 1 Piping Diagrams

7

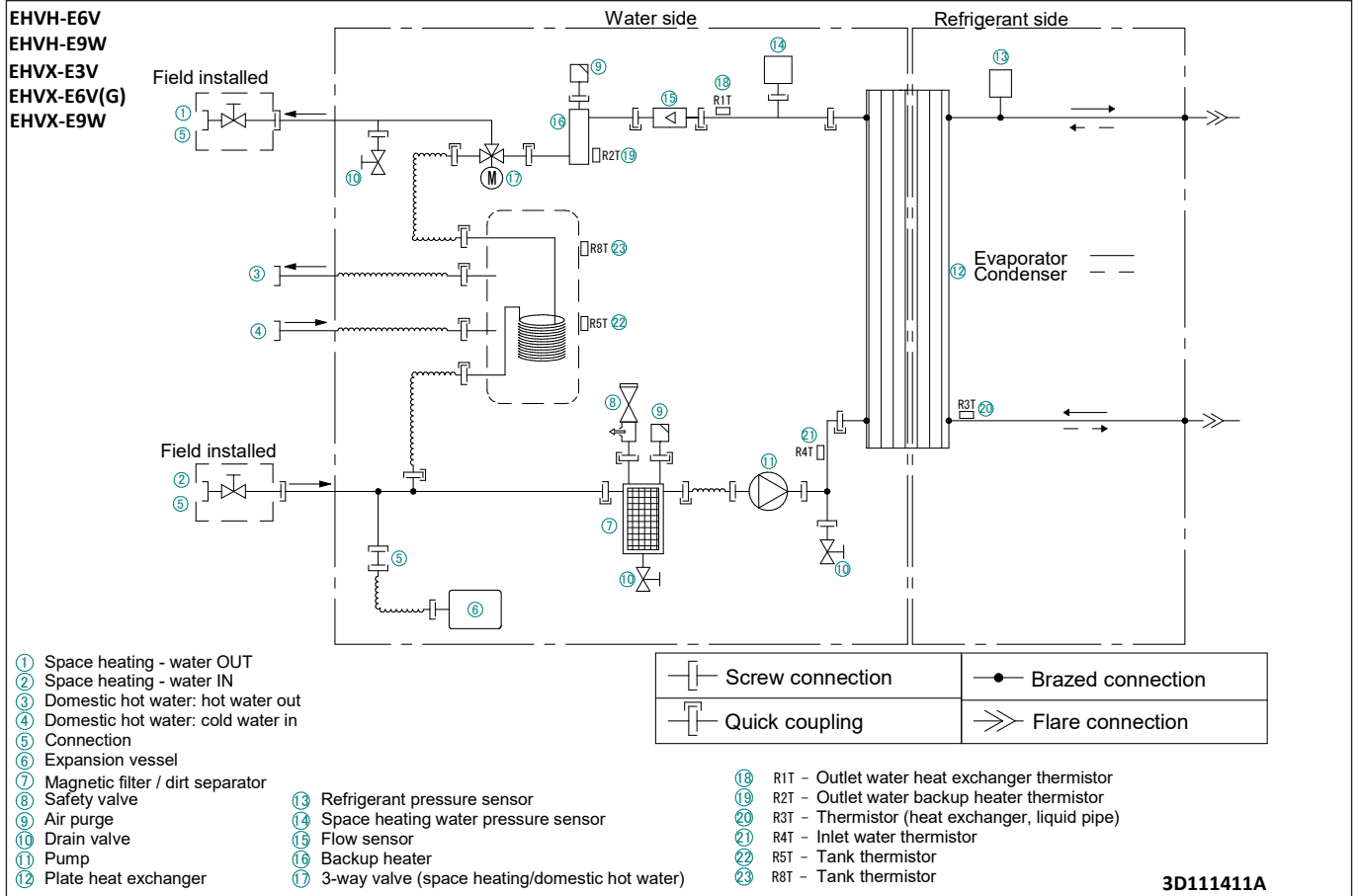

# 8 Wiring diagrams

## 8 - 1 Notes & Legend

### EHVH-E6V / EHVH-E9W / EHVH-UE6V / EHVX-E6V / EHVX-E9W

#### NOTES to go through before starting the unit

- X1M : Main terminal
- X2M : Field wiring terminal for AC
- X5M : Field wiring terminal for DC
- X6M : BUH Power supply terminal
- X10M : Smartgrid terminal
- ..... : Earth wiring
- : Field supply
- ① : Several wiring possibilities

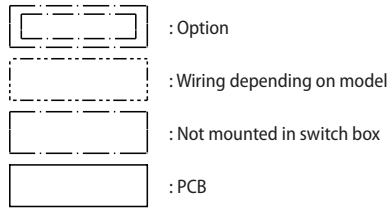

#### NOTES

1. Connection point of the power supply for the BUH should be foreseen outside the unit.

- Backup heater power supply
- 3V (1N~, 230V, 3kW)
  - 6T1 (3~, 230V, 6kW)
  - 6V3 (1N~, 230V, 6kW)
  - 6WN/9WN (3N~, 400V, 6/9kW)
- User installed options:
- LAN adapter
  - Remote user interface
  - Ext. indoor thermistor
  - Ext. outdoor thermistor
  - Digital I/O PCB
  - Demand PCB
  - Safety thermostat
  - Smartgrid kit
  - WLAN adapter module
  - WLAN cartridge
- Main LWT:
- ON/OFF thermostat (wired)
  - ON/OFF thermostat (wireless)
    - Ext. thermistor
  - Heat pump convector
- Add LWT:
- ON/OFF thermostat (wired)
  - ON/OFF thermostat (wireless)
    - Ext. thermistor
  - Heat pump convector

#### POSITION IN SWITCH BOX

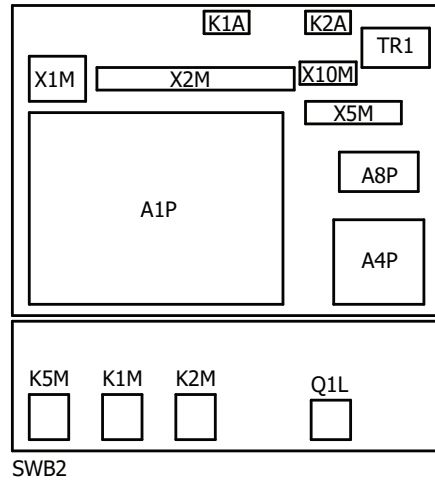

#### LEGEND

Part n°	Description	Part n°	Description
A1P	main PCB	P1M	MMI display
A2P	* ON/OFF thermostat (PC=power circuit)	PC (A15P)	* power circuit
A3P	* heat pump convector	PHC1 (A4P)	* optocoupler input circuit
A4P	* digital I/O PCB	Q1L	thermal protector backup heater
A8P	* demand PCB	Q4L	# safety thermostat
A9P	status indicator	Q*DI	# earth leakage circuit breaker
A11P	MMI main PCB	R1H (A2P)	* humidity sensor
A13P	* LAN adapter	R1T (A1P)	outlet water heat exchanger thermistor
A14P	* user interface PCB	R1T (A2P)	* ambient sensor ON/OFF thermostat
A15P	* receiver PCB (wireless ON/OFF thermostat)	R1T (A14P)	* ambient sensor user interface
A20P	* WLAN module	R2T (A1P)	outlet backup heater thermistor
B2L	flow sensor	R2T (A2P)	* external sensor (floor or ambient)
B1PR	refrigerant pressure sensor	R3T	refrigerant liquid side thermistor
B1PW	water pressure sensor	R4T	inlet water thermistor
CN* (A4P)	* connector	R5T, R8T	domestic hot water thermistor
DS1 (A8P)	* dipswitch	R6T	* external indoor or outdoor ambient thermistor
E1H	backup heater element (1 kW)	S15	# preferential kWh rate PS contact
E2H	backup heater element (2 kW)	S25	# electrical meter pulse input 1
E*P (A9P)	indication LED	S35	# electrical meter pulse input 2
F1B	# overcurrent fuse backup heater	S45	# smart grid feed-in
F1T	thermal fuse backup heater	S65-S95	* digital power limitation inputs
F1U, F2U (A4P)	* fuse 5 A 250 V for digital I/O PCB	S105-S115	# low voltage smartgrid contact
FU1 (A1P)	fuse T 6.3 A 250 V for PCB	SS1 (A4P)	* selector switch
K1A, K2A	* high voltage smartgrid relay	SW1~2 (A11P)	turn buttons
K1M, K2M	contactor backup heater	SW3~5 (A11P)	push button
K5M	safety contactor BUH	TR1	power supply transformer
K*R (A1P-A4P)	relay on PCB	X6M	# BUH power supply terminal strip
M1P	main supply pump	X10M	* smartgrid power supply terminal strip
M2P	# domestic hot water pump	X*, X*A, X*H*, X*Y	connector
M2S	# 2 way valve for cooling mode	X*M	terminal strip
M3S	3 way valve for spaceheating/ domestic hot water		

\*: optional #: field supply

4D130329D



# 8 Wiring diagrams

## 8 - 2 Control Circuit

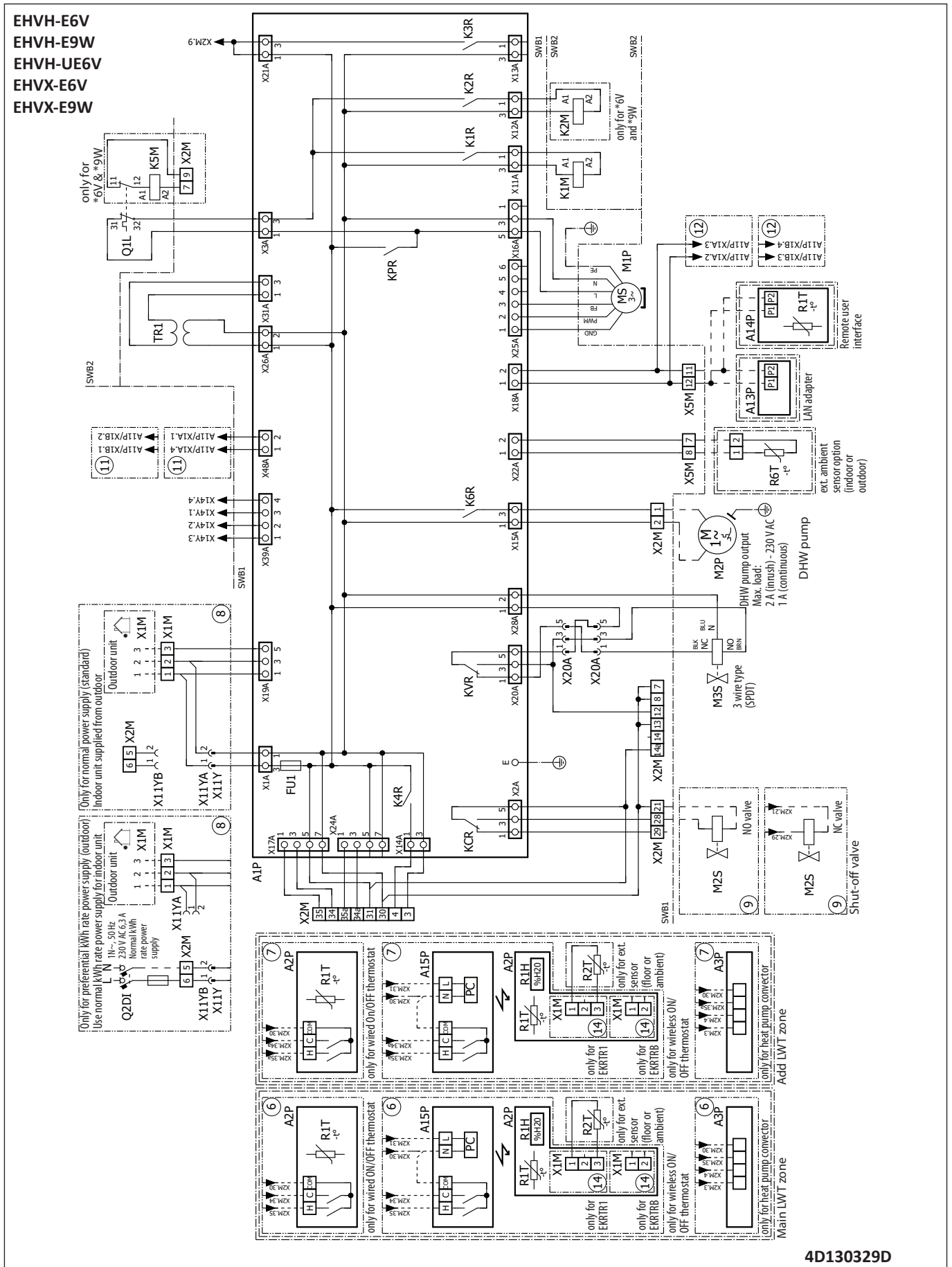

# 8 Wiring diagrams

## 8 - 2 Control Circuit

8

EHVH-E6V  
EHVH-E9W  
EHVH-UE6V  
EHVX-E6V  
EHVX-E9W

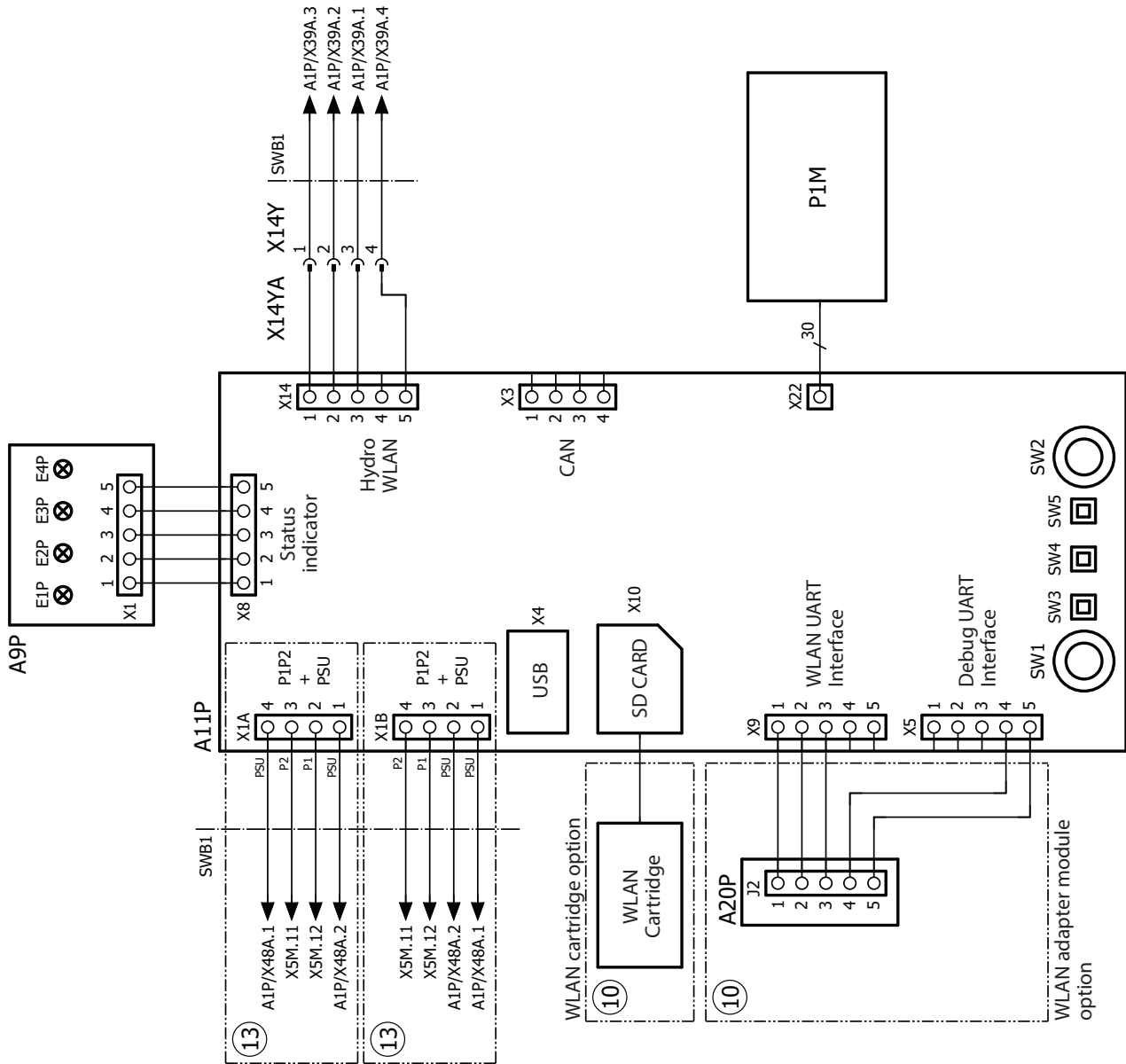

4D130329D

# 8 Wiring diagrams

## 8 - 3 Power Supply, Back-up Heater

EHVH-E6V  
EHVH-E9W  
EHVH-UE6V  
EHVX-E6V  
EHVX-E9W

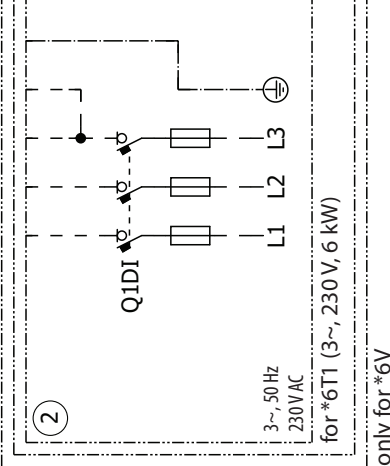
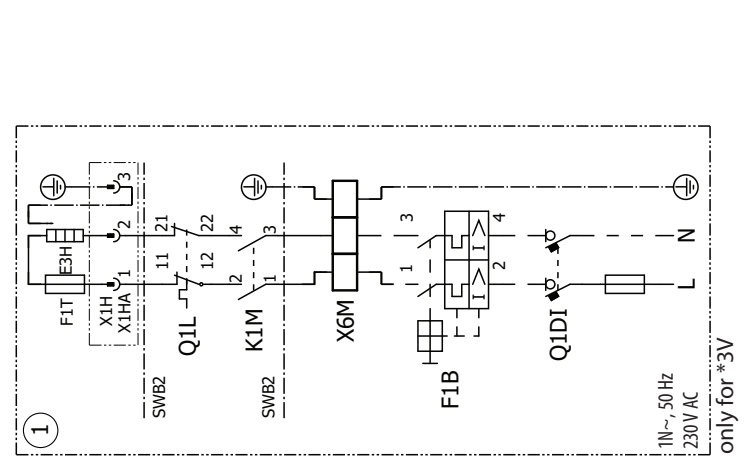
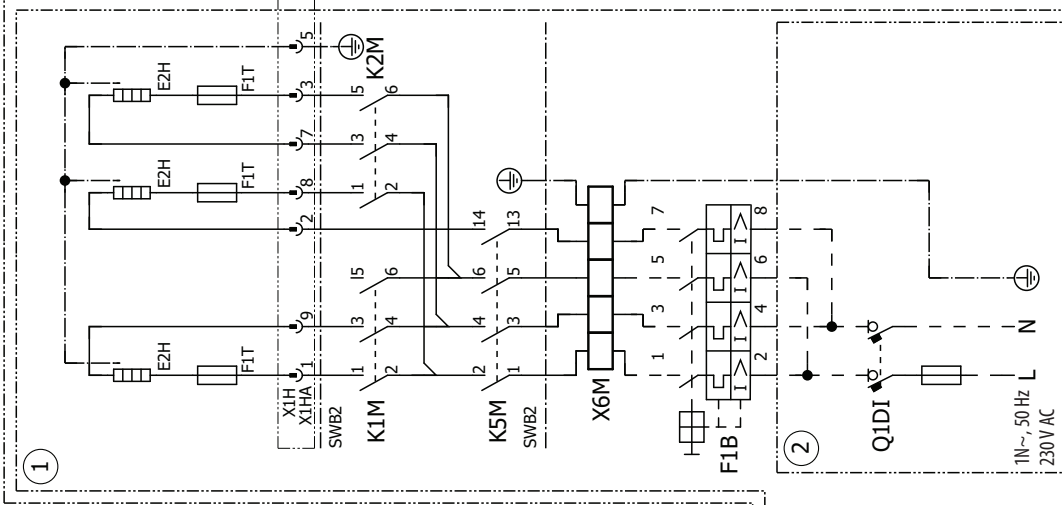
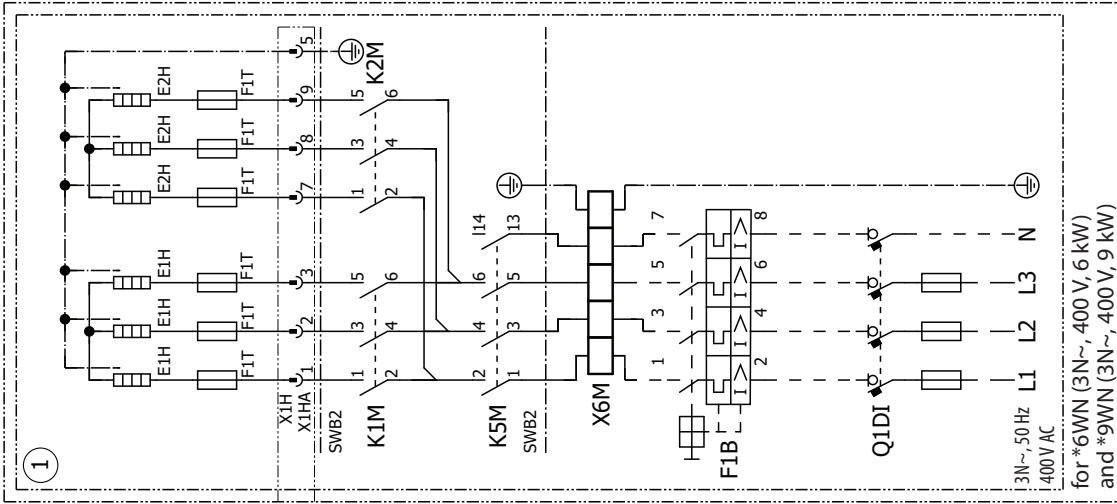
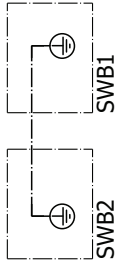

4D130329D

# 9 External connection diagrams

## 9 - 1 External Connection Diagrams

9

**EHVH-E6V**  
**EHVH-E9W**  
**EHVH-UE6V**  
**EHVX-E6V**  
**EHVX-E9W**

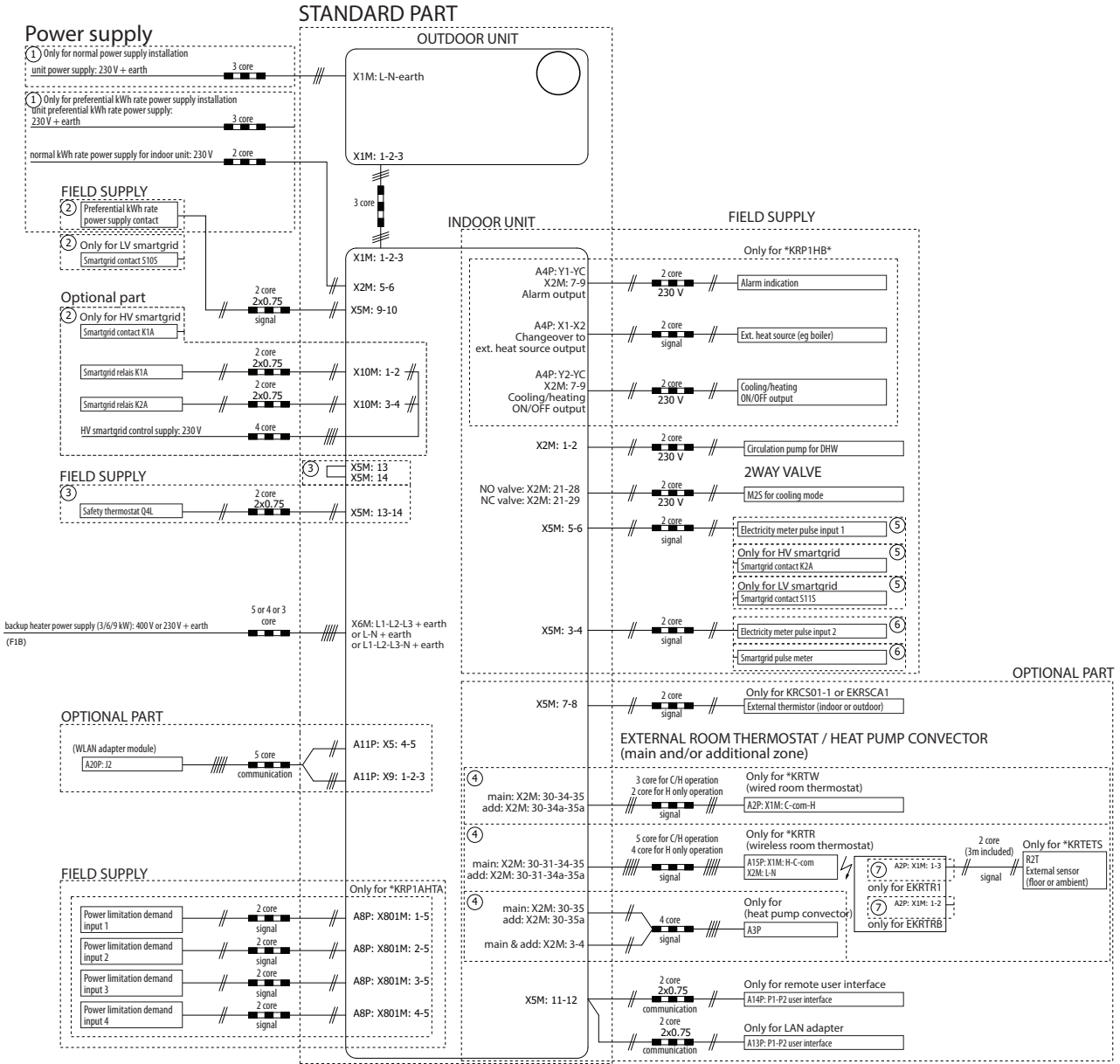

4D130331D

# 10 Installation

## 10 - 1 Installation Method

EHVH-E6V  
EHVH-E9W  
EHVX-E3V  
EHVX-E6V(G)  
EHVX-E9W

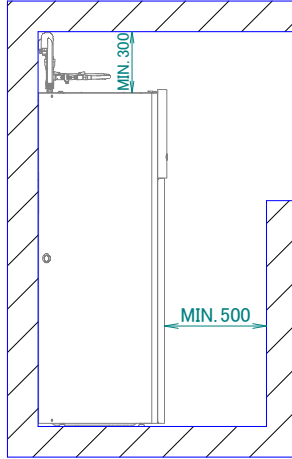
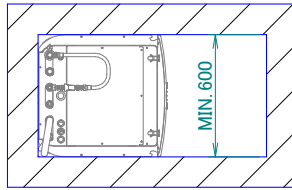

3D112073A

# 11 Operation range

## 11 - 1 Operation Range

11

EHVX-E3V  
EHV(H-X-Z)-E6V  
EHV(H-X-Z)-E9W  
EHVX-E6VG

### Heat-up times

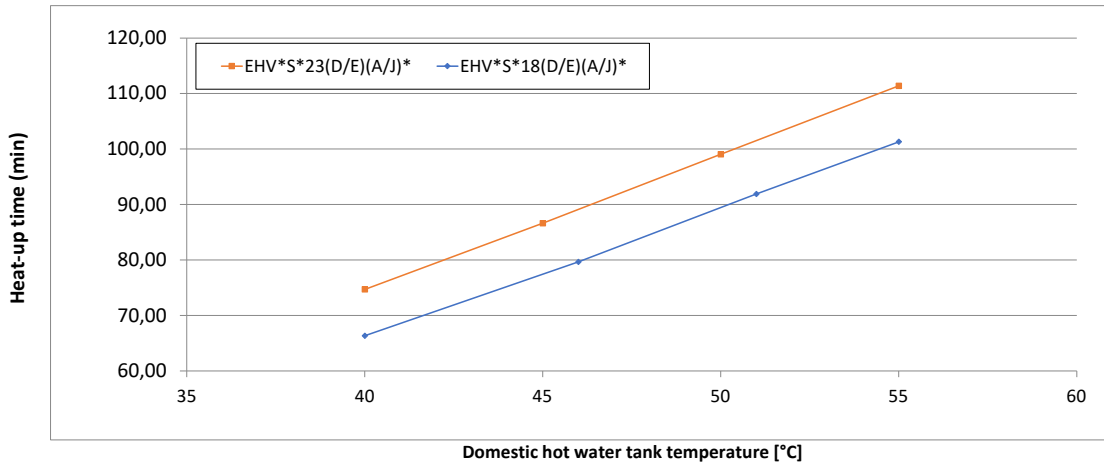

Heat-up time domestic hot water tank until 45°C	
EHV*04S*18(D/E)(A/J)*	·79· min.
EHV*08S*23(D/E)(A/J)*	·87· min.

### Notes

1. Time the indoor unit (**heat pump only operation**) requires to heat up the domestic hot water tank from 10°C to the indicated temperature.  
See the operation range for maximum domestic hot water tank temperature during heat pump only operation.

4D113329C

EHVX-E3V  
EHV(H-X-Z)-E6V  
EHV(H-X-Z)-E9W  
EHVX-E6VG

### Selection guide for the domestic hot water tank volume

(1)

Veq 40°C = the amount of water with a temperature of 40°C that can be tapped when the domestic hot water tank is heated to a certain temperature, and the temperature of the cold inlet water is 10°C.

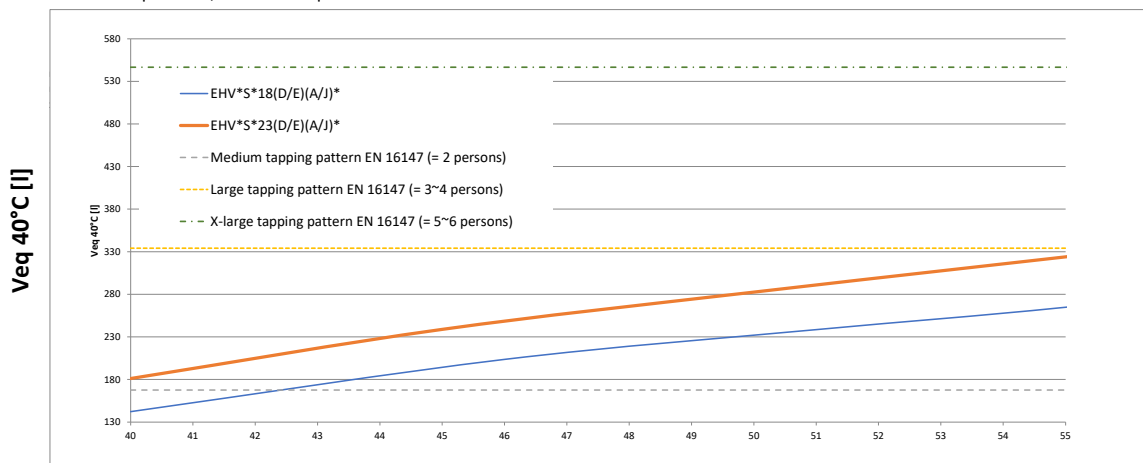

If a higher daily Veq 40°C is required, then additional heat-up cycles are required within 24 hours.

See the operation manual for more information.

### Notes

- (1) According to EN16147.

4D113329C

# 11 Operation range

## 11 - 1 Operation Range

**EHBH-E6V / EHBH-E9W / EHBX-E6V / EHBX-E9W**  
**EHSB-E / EHSB-E / EHSX-E / EHSXB-E**  
**EHVH-E6V / EHVH-E9W / EHVH-UE6V / EHVX-E3V**  
**EHVX-E6V / EHVX-E9W / EHVZ-E6V / EHVZ-E9W**

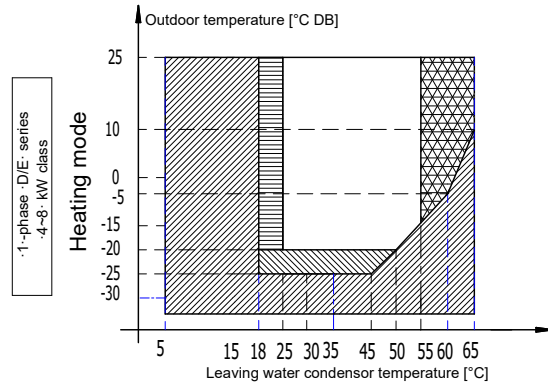
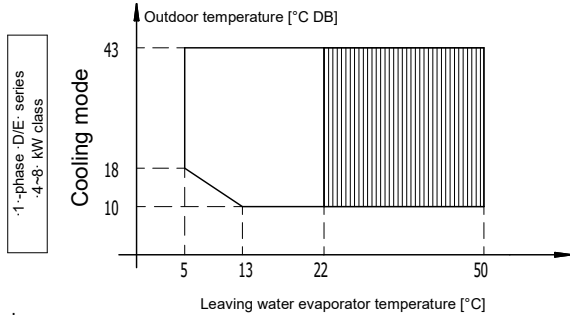

### Legend

- Backup heater only operation  
No outdoor unit operation
- Outdoor unit operation if setpoint  $\geq -25^{\circ}\text{C}$
- Operation of outdoor unit possible, but with possible capacity reduction.  
If the outdoor temperature  $< -25^{\circ}\text{C}$ , the outdoor unit will stop.  
Indoor unit and backup heater operation will continue.
- Pull-down area
- Outdoor unit operation if setpoint  $> -55^{\circ}\text{C}$  and  $\Delta T = -10^{\circ}\text{C}$  ( $\Delta T = \text{outlet temperature} - \text{inlet temperature}$ )

### Remark

In restricted power supply mode, the outdoor unit, booster heater and backup heater can only operate separately.

### Warning

In areas with low ambient temperatures and high humidity, or in areas with heavy snowfall, remove the suction grille to ensure proper operation.

Non-exhaustive list of areas: Austria, Czech Republic, Denmark, Estonia, Finland, Germany, Hungary, Latvia, Lithuania, Norway, Poland, Romania, Serbia, Slovakia, Sweden, ...

Indoor  
 ·D/E(A/F/J)· series Standard

3D111563D

# 12 Hydraulic performance

## 12 - 1 Static Pressure Drop Unit

12

EHVH-E6V  
 EHVH-E9W  
 EHVX-E3V  
 EHVX-E6V(G)  
 EHVX-E9W

**EHV(H/X)(04/08)\*(D/E)(A/J)\***

Operation area

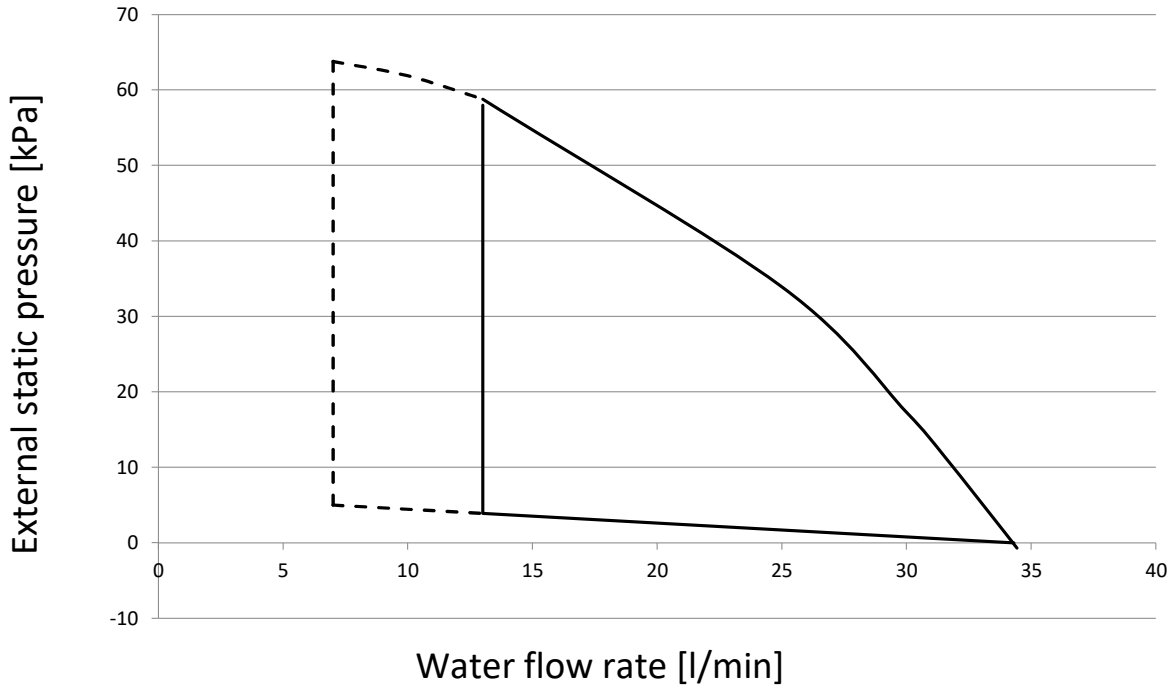

Operation area is extended to lower flow rates only in case the unit operates with heat pump only.  
 (Not in startup, no BUH operation, no defrost operation.)

See dashed lines

Notes

<sup>1</sup> Selecting a flow outside the operating area can damage the unit or cause the unit to malfunction.

See also the minimum and maximum allowed water flow range in the technical specifications.

<sup>2</sup> Water quality must be according to EU directive 98/83 EC.

**4D112012B**

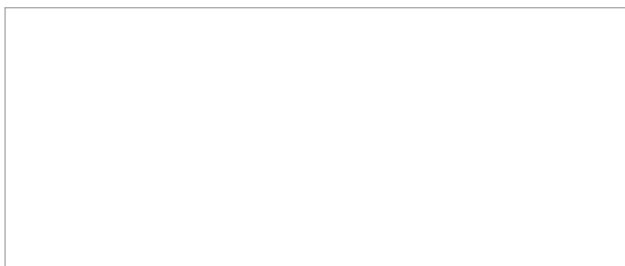

EEEDEN22

09/2022



The present leaflet is drawn up by way of information only and does not constitute an offer binding upon Daikin Europe N.V. Daikin Europe N.V. has compiled the content of this leaflet to the best of its knowledge. No express or implied warranty is given for the completeness, accuracy, reliability or fitness for particular purpose of its content and the products and services presented therein. Specifications are subject to change without prior notice. Daikin Europe N.V. explicitly rejects any liability for any direct or indirect damage, in the broadest sense, arising from or related to the use and/or interpretation of this leaflet. All content is copyrighted by Daikin Europe N.V.