



Air Conditioning Technical Data RXC-D

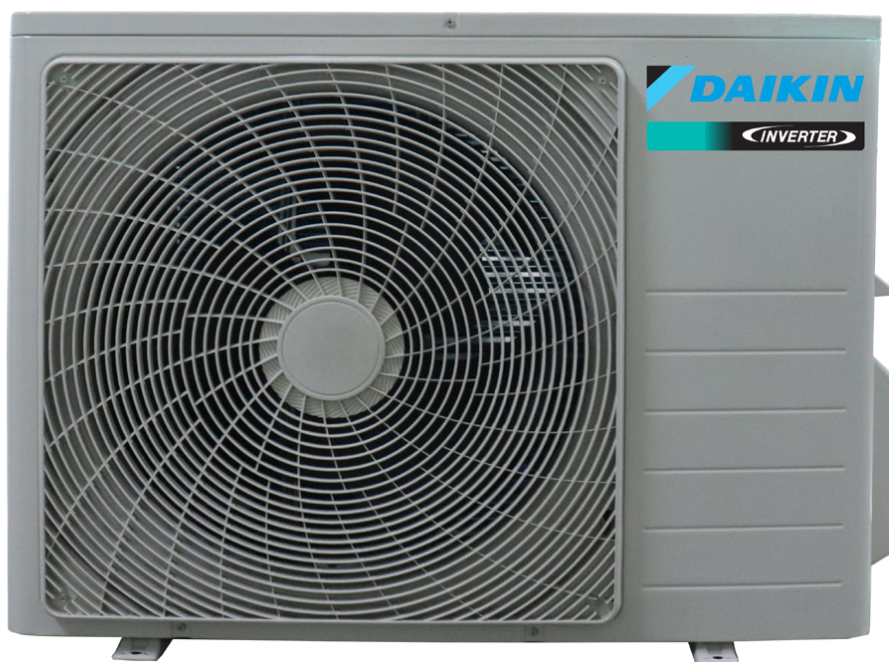

TABLE OF CONTENTS

RXC-D

1	Features	4
	RXC-D	4
2	Specifications	5
3	Electrical data	9
4	Capacity tables	10
	Cooling Capacity Tables	10
5	Dimensional drawings	13
6	Piping diagrams	16
7	Wiring diagrams	18
	Wiring Diagrams - Three Phase	18
8	Sound data	19
	Sound Pressure Spectrum	19
9	Operation range	22

1 Features

1 - 1 RXC-D

- › Daikin outdoor units are neat, sturdy and can easily be mounted on a roof or terrace or simply placed against an outside wall
- › Outdoor units for pair application
- › Daikin outdoor units are equipped with an anti-corrosion treated heat exchanger (blue fin) which ensures greater resistance to the most severe weather conditions
- › Choosing for an R-32 product, reduces the environmental impact with 68% compared to R-410A and leads directly to lower energy consumption thanks to its high energy efficiency



Inverter

2 Specifications

2 - 1 Specifications

Technical specifications			FTXC20D + RXC20D	FTXC25D + RXC25D	FTXC35D + RXC35D	FTXC50D + RXC50D	FTXC60D + RXC60D	FTXC71D + RXC71D
Indoor unit			FTXC20DV1B	FTXC25DV1B	FTXC35DV1B	FTXC50DV1B	FTXC60DV1B	FTXC71DV1B
Outdoor unit			RXC20DV1B	RXC25DV1B	RXC35DV1B	RXC50DV1B	RXC60DV1B	RXC71DV1B
Cooling capacity	Min.	kW	1.3			1.4	1.8	2.3
	Min.	Btu/h	4,400.0			4,700.0	6,100.0	7,800.0
	Rated	kW	2.00	2.56	3.50	5.10	6.23	7.10
	Rated	Btu/h	6,800.00	8,700.00	11,900.00	17,400.00	21,300.00	24,200.00
	Max.	kW	3.0			4.0	6.2	7.3
	Max.	Btu/h	10,200.0			13,600.0	21,200.0	23,900.0
Cooling capacity - Low sound mode (Stb. 2020, 189)	Min.	kcal/h	-					
	Max.	kcal/h	-					
Heating capacity	Min.	kW	1.30			1.36	1.48	2.30
	Min.	Btu/h	4,400.0			4,600.0	5,000.0	7,800.0
	Rated	kW	2.50	2.84	4.00	5.62	6.40	8.00
	Rated	Btu/h	8,500.00	9,700.00	13,600.00	19,200.00	21,800.00	27,300.00
	Max.	kW	4.00			4.80	8.00	9.00
	Max.	Btu/h	13,600.0			16,400.0	22,500.0	27,300.0
Power input	Cooling	Min.	0.30			0.32	0.30	0.44
		Nom.	0.595	0.765	1.05	1.55	1.89	2.38
		Max.	1.15			1.74	2.11	2.54
	Heating	Min.	0.28			0.27	0.33	0.50
		Nom.	0.670	0.750	1.07	1.52	1.68	2.46
		Max.	1.35			1.57	1.85	2.35
Nominal efficiency	EER	3.36	3.35			3.29	3.30	2.98
	COP	3.73	3.79	3.74	3.71	3.81	3.25	
	Energy labeling Directive	Cooling	A					C
		Heating	A					C
Space cooling	Energy efficiency class		A++					A
	Capacity Pdesign	kW	2.08	2.57	3.44	5.08	6.21	6.96
	SEER		6.89	6.84	6.87	6.45	6.40	5.30
	Annual energy consumption	kWh/a	106	131	175	276	339	460
Space heating (Average climate)	Capacity Pdesign	kW	1.87	2.23	2.24	3.90	4.10	6.35
	Energy efficiency class		A+					A
	SCOP/A		4.40	4.45	4.28	4.42	4.24	3.81
	Pdh Heating capacity at -10°	kW	1.38	1.57	1.71	2.99	3.49	5.36
	Annual energy consumption	kWh/a	595	701	733	1,234	1,353	2,332
	Required back up heating cap at design conditions	kW	0.480	0.660	0.520	0.910	0.610	0.990
Space heating (Warm climate)	Capacity Pdesignh	kW	2.01	2.05	2.06	4.46	5.53	5.84
	Energy efficiency class		A+++					A++
	SCOP		5.78	5.81	5.69	5.32	5.38	4.60
	Annual energy consumption	kWh/a	487	494	507	1,173	1,439	1,776
	Required back up heating cap at design conditions	kW	0.00					
Space cooling	A Condi- tion (35°C - 27/19)	Pdc	2.08	2.57	3.44	5.08	6.21	6.96
		EERd	3.95	3.28	3.26	3.20	3.28	2.69
	B Condi- tion (30°C - 27/19)	Pdc	1.60	1.80	2.41	3.75	4.73	5.21
		EERd	5.77	5.55	5.21	4.81	4.97	4.32
	C Condi- tion (25°C - 27/19)	Pdc	1.29	1.28	1.57	2.29	3.08	3.46
		EERd	9.51	9.25	8.81	7.99	8.04	6.71
	D Condi- tion (20°C - 27/19)	Pdc	0.136	0.138	0.178	0.287	0.383	0.516
		EERd	1.35		1.31	1.82	2.30	2.22
		Pdc	12.48	11.9	12.85	11.75	11.25	7.83
		Power input	0.108	0.113	0.102	0.155	0.204	0.284

2 Specifications

2 - 1 Specifications

2

Technical specifications				FTXC20D + RXC20D	FTXC25D + RXC25D	FTXC35D + RXC35D	FTXC50D + RXC50D	FTXC60D + RXC60D	FTXC71D + RXC71D
Space heating (Average climate)	TOL	Tol (temperature operating limit) °C		-14					
		PdH (declared heating cap) kW		1.03		1.36	2.37	3.30	5.02
		COPd (declared COP)		1.94	1.93		1.90	2.49	2.38
	Power input kW		0.531	0.536	0.705	1.247	1.325	2.109	
	TBivalent	Tbiv (bivalent temperature) °C		-7					
		PdH (declared heating cap) kW		1.65	1.97	1.98	3.45	3.63	5.62
		COPd (declared COP)		2.49	2.93	2.45	2.55	2.71	2.52
	Power input kW		0.663	0.672	0.808	1.353	1.339	2.230	
	A Con- dition (-7°C)	PdH (declared heating cap) kW		1.65	1.97	1.98	3.45	3.63	5.62
		COPd (declared COP)		2.49	2.93	2.45	2.55	2.71	2.52
		Power input kW		0.663	0.672	0.808	1.353	1.339	2.230
	B Condi- tion (2°C)	PdH (declared heating cap) kW		1.05	1.19	1.26	2.01	2.16	3.33
		COPd (declared COP)		4.65	4.33	4.51	4.76	4.42	3.69
		Power input kW		0.226	0.269	0.279	0.423	0.489	0.902
	C Condi- tion (7°C)	PdH (declared heating cap) kW		0.900		0.990	1.58	1.74	2.30
		COPd (declared COP)		6.12	6.08	5.81	5.64	5.41	5.11
Power input kW		0.147	0.148	0.170	0.280	0.322	0.450		
D Con- dition (12°C)	PdH (declared heating cap) kW		1.11			1.77	1.78	1.80	
	COPd (declared COP)		7.66	7.58	7.15	7.13	6.70	5.95	
	Power input kW		0.145	0.146	0.155	0.248	0.266	0.303	
Space heating (Warm climate)	TBivalent	Tbiv (bivalent temperature) °C		2					
		PdH (declared heating cap) kW		2.01	2.05	2.06	4.46	5.53	5.84
		COPd (declared COP)		3.16		3.42	2.68	2.80	2.61
	Power input kW		0.636	0.649	0.602	1.664	1.979	2.233	
	B Condi- tion (2°C)	PdH (declared heating cap) kW		2.01	2.05	2.06	4.46	5.53	5.84
		COPd (declared COP)		3.16		3.42	2.68	2.80	2.61
		Power input kW		0.636	0.649	0.602	1.664	1.975	2.233
	C Condi- tion (7°C)	PdH (declared heating cap) kW		1.24	1.26	1.39	2.88	3.65	3.85
		COPd (declared COP)		5.87	5.97	6.00	4.91	5.15	4.61
		Power input kW		0.211		0.232	0.587	0.709	0.836
	D Con- dition (12°C)	PdH (declared heating cap) kW		1.11			1.77	1.78	1.80
		COPd (declared COP)		7.66	7.58	7.15	7.13	6.80	5.28
Power input kW		0.145	0.146	0.155	0.248	0.262	0.341		
Power consump- tion in other than active mode	Crank- case heater mode	PCK		0.00					
		Off mode POFF		2.00					
	Standby mode	Cooling	PSB	2.00					
		Heating	PSB	2.0					
Cooling	Cdc (Degradation cooling)			0.25					
Heating	Cdh (Degradation heating)			0.25					
Cooling function included				Yes					
Heating function included				Yes					
Average climate included				Yes					
Cold season included				No					
Warm season included				Yes					
Ecolabel logo				No					
Eurovent	Sound power level outdoor	Cooling	Nom.	dB(A)	58	60	65	66	69
		Cooling	Nom.	dB(A)	57	58	60	63	
	Sound power level indoor								

Electrical specifications				FTXC20D + RXC20D	FTXC25D + RXC25D	FTXC35D + RXC35D	FTXC50D + RXC50D	FTXC60D + RXC60D	FTXC71D + RXC71D
Current	Nominal running current (RLA)	Cooling	A	3.00	3.04	4.20	6.24	7.22	8.98
	Nominal running current (RLA) - 50Hz	Heating	A	2.73	3.02	4.34	5.97	6.31	9.38
Current - 50Hz	Maximum running current			6.9		7.9	10.2	11.5	
	Maximum fuse amps (MFA)			16					

Technical Specifications				RXC20D	RXC25D	RXC35D	RXC50D	RXC60D	RXC71D
Casing	Colour			Ivory white					
	Material			Sheet metal					

2 Specifications

2 - 1 Specifications

Technical Specifications				RXC20D	RXC25D	RXC35D	RXC50D	RXC60D	RXC71D	
Dimensions	Unit	Height	mm	550			615		695	
		Width	mm	658			845		930	
		Depth	mm	273			300		350	
	Packed unit	Height	mm	610			679		760	
		Width	mm	781			992		1,084	
		Depth	mm	363			414		473	
Weight	Unit	kg		24.0	26.0		39.0	45.0		
	Packed unit	kg		26	28		43	49		
Packing	Material	EPS-Foam / Corrugated board								
	Weight	kg		2			4			
Heat exchanger	Length	mm		662	627		850		878	
	Rows	Quantity		1			2			
	Fin pitch	mm		18.0						
	Face area	m ²		0.330	0.320		0.500		0.590	
	Stages	Quantity		24			28		32	
	Tube type	Inner Groove								
	Tube material	Copper								
	Tube diameter	mm		7						
	Fin	Type		Aluminium (Corrugated)						
		Treatment		Hydrophilic						
	Fan	Type	Propeller fan							
Discharge direction		Horizontal								
Quantity		1								
Air flow rate		Cooling	High	m ³ /min	26.3	23.8		37.1	46.2	54.7
				cfm	930	840		1,310	1,630	1,930
Running current	Cooling	Medium	A	0.3			0.4	0.6	1.0	
Fan motor	Quantity	1								
	Model				M3SLY10/15F-1		M3SLY20F-1		M3SLY30F-1	
	Index of Protection				24		23			
	Insulation grade	Class "E"								
	Poles	8								
	Output	W			26			61	128	
	Drive	Direct drive								
	Speed	Cooling	High	rpm	930			900	1,100	800
Compressor	Quantity	1								
	Model				1GDY25BXD		2YC40GXD			
	Oil Amount	cm ³		375			650			
	Type	Hermetic swing								
Operation range	Cooling	Ambient	Min.	°CDB	10			-10		
			Max.	°CDB				46		
	Heating	Ambient	Min.	°CWB	-15					
			Max.	°CWB	18					
	Sound power level	Cooling			dB	58	60	65	66	69
Sound pressure level	Cooling	High			dB	45	46	51	54	
Refrigerant	Type	R-32								
	Charge	kg		0.550	0.750		1.00	1.10	1.15	
	Control	EXV								
	GWP	675.0								
Piping connections	Liquid	Type	Flare connection							
		OD	mm	6.35						
	Gas	Quantity	1							
		Type	Flare connection							
		OD	mm	9.52			12.7			
	Drain	Quantity	1							
		Type	Drain Joint							
		OD	mm	16						
	Piping length	OU - IU	Min.	m	3					
			Max.	m	20			30		
		System	Chargeless	m	8					
Additional refrigerant charge			kg/m	0,017 (for piping length exceeding 7.5m)						
Level difference	IU - OU	Max.	m	15.0			20.0			
Heat insulation	Both liquid and gas pipes									
Defrost method	Temperature									
Defrost control	Outdoor heat exchanger and ambient sensor									
Capacity control	Method	Inverter controlled								

2 Specifications

2 - 1 Specifications

2

Electrical Specifications				RXC20D	RXC25D	RXC35D	RXC50D	RXC60D	RXC71D
Power supply	Name			V1					
	Phase			1~					
	Frequency	Hz		50					
	Voltage	V		220-240					
Current	Nominal running current (RLA)	Cooling	A	3.00	3.04	4.20	6.24	7.22	8.98
		Heating	A	2.73	3.02	4.34	5.97	6.31	9.38
	Maximum running current	Cooling	A	6.2		6.7	10.2	10.5	11.5
		Heating	A	6.9		7.9	10.2	11.5	
Wiring connections	For power supply	Quantity	3						
		Remark	3 for power supply, 4 for interunit wiring (including earth wiring)						
	For connection with indoor	Quantity	4						
		Remark	Earth wire included						
Current - 50Hz	Maximum fuse amps (MFA)	A	16						

3 Electrical data

3 - 1 Electrical Data

FTXC-D / RXC-D

Unit combination restrictions		Power supply						COMP				OFM				IFM				
Indoor unit	Outdoor unit	①	②	③	MCA		MFA		Cooling		Heating		Cooling		Heating		Cooling		Heating	
					Cooling	Heating	Cooling	Heating	RHz	RLA	RHz	RLA	kW	FLA	kW	FLA	kW	FLA	kW	FLA
FTXC20DV1B	RXC20DV1B	50	220 230 240	Max. 50Hz 264V Min. 50Hz 198V	6.16	6.91	16	16	33	3.00	50	2.73	0.026	0.28	0.026	0.28	0.038	0.15	0.038	0.15
FTXC25DV1B	RXC25DV1B	50	220 230 240	Max. 50Hz 264V Min. 50Hz 198V	6.16	6.91	16	16	47	3.04	55	3.02	0.026	0.28	0.026	0.28	0.038	0.15	0.038	0.15
FTXC35DV1B	RXC35DV1B	50	220 230 240	Max. 50Hz 264V Min. 50Hz 198V	6.68	7.93	16	16	65	4.20	75	4.34	0.026	0.32	0.026	0.32	0.038	0.16	0.038	0.16
FTXC50DV1B	RXC50DV1B	50	220 230 240	Max. 50Hz 264V Min. 50Hz 198V	10.20	10.20	16	16	67	6.24	65	5.97	0.061	0.38	0.061	0.49	0.038	0.20	0.038	0.20
FTXC60DV1B	RXC60DV1B	50	220 230 240	Max. 50Hz 264V Min. 50Hz 198V	10.50	11.50	16	16	76	7.22	79	6.31	0.061	0.62	0.061	0.62	0.038	0.45	0.038	0.45
FTXC71DV1B	RXC71DV1B	50	220 230 240	Max. 50Hz 264V Min. 50Hz 198V	11.50	11.50	16	16	92	8.98	92	9.38	0.128	0.97	0.128	0.97	0.038	0.45	0.038	0.45

SYMBOLS

- ① Hz
- ② Voltage
- ③ Voltage range
- MCA : Minimum circuit ampere (A)
- MFA : Maximum fuse ampere (A)
- RLA : Rated load amps (A)
- COMP : Compressor
- OFM : Outdoor fan motor
- IFM : Indoor fan motor
- FLA : Full load ampere (A)
- kW : Fan motor rated output (kW)
- RHz : Rated operating frequency (Hz)

NOTES

1. The RLA is based on the following conditions.
 - Indoor temperatures 27°CDB / 19°CWB
 - Outdoor temperature 35°C DBB
2. Select the wire size according to the MCA.
3. The maximum allowable voltage that is unbalanced between phases is 2%.
4. Use a circuit breaker instead of a fuse.

3D140571A

4 Capacity tables

4 - 1 Cooling Capacity Tables

4

FTXC20D / RXC20D

Cooling: 220 - 240V 50Hz

AFR	10.8
BF	0.28

Indoor Temperature		Outdoor Temperature [°C DB]																	
EWB °C	EDB °C	20			25			30			32			35			40		
		TC	SHC	PI	TC	SHC	PI	TC	SHC	PI	TC	SHC	PI	TC	SHC	PI	TC	SHC	PI
14	20	2.05	1.97	0.46	1.95	1.91	0.50	1.86	1.85	0.54	1.82	1.83	0.56	1.77	1.78	0.59	1.67	1.72	0.63
16	22	2.14	1.94	0.46	2.05	1.88	0.50	1.95	1.82	0.55	1.92	1.80	0.57	1.86	1.76	0.59	1.77	1.71	0.64
18	25	2.24	2.03	0.46	2.14	1.97	0.51	2.05	1.92	0.55	2.01	1.89	0.57	1.95	1.86	0.60	1.86	1.81	0.64
19	27	2.28	2.13	0.46	2.19	2.07	0.51	2.09	2.02	0.55	2.06	2.00	0.57	2.00	1.97	0.60	1.91	1.92	0.64
22	30	2.42	2.05	0.47	2.33	2.00	0.51	2.23	1.96	0.55	2.19	1.94	0.57	2.14	1.91	0.60	2.05	1.87	0.64
24	32	2.51	2.00	0.47	2.42	1.95	0.51	2.33	1.91	0.56	2.29	1.89	0.58	2.23	1.87	0.60	2.14	1.82	0.65

Heating: 220 - 240V 50Hz

AFR	10.8
-----	------

Indoor Temperature		Outdoor Temperature [°C WB]											
EDB °C	°C	-15		-10		-5		0		6		10	
		TC	PI	TC	PI	TC	PI	TC	PI	TC	PI	TC	PI
15		1.19	0.43	1.43	0.45	1.67	0.48	1.91	0.62	2.59	0.66	2.81	0.68
20		1.12	0.44	1.36	0.46	1.60	0.48	1.84	0.64	2.50	0.67	2.73	0.69
22		1.09	0.45	1.33	0.47	1.57	0.49	1.81	0.64	2.46	0.67	2.69	0.70
24		1.06	0.45	1.30	0.48	1.54	0.50	1.78	0.65	2.43	0.68	2.66	0.70
25		1.04	0.45	1.28	0.48	1.53	0.50	1.77	0.65	2.41	0.68	2.64	0.71
27		1.01	0.46	1.26	0.48	1.49	0.50	1.74	0.66	2.38	0.69	2.61	0.71

SYMBOLS

- AFR : Air flow rate (m³/min.)
- BF : Bypass factor
- EWB : Entering wet bulb temp. (°C)
- EDB : Entering dry bulb temp. (°C)
- TC : Total capacity (kW)
- SHC : Sensible heat capacity (kW)
- PI : Power input (kW)

NOTES

1. shows nominal (rated) capacities and power input.
2. TC, PI and SHC must be calculated by interpolation using the figures in the above tables.
3. Capacities are based on the following conditions.
Corresponding refrigerant piping length: 7.5m
Level difference: 0.0m

3D121043B

FTXC25D / RXC25D

Cooling: 220 - 240V 50Hz

AFR	10.8
BF	0.17

Indoor Temperature		Outdoor Temperature [°C DB]																	
EWB °C	EDB °C	20			25			30			32			35			40		
		TC	SHC	PI	TC	SHC	PI	TC	SHC	PI	TC	SHC	PI	TC	SHC	PI	TC	SHC	PI
14	20	2.62	2.40	0.59	2.50	2.33	0.64	2.38	2.25	0.70	2.34	2.22	0.72	2.26	2.17	0.76	2.14	2.10	0.81
16	22	2.74	2.36	0.59	2.62	2.29	0.65	2.50	2.22	0.70	2.46	2.19	0.73	2.38	2.15	0.76	2.26	2.08	0.82
18	25	2.86	2.47	0.59	2.74	2.40	0.65	2.62	2.33	0.71	2.57	2.31	0.73	2.50	2.27	0.77	2.38	2.20	0.82
19	27	2.92	2.59	0.59	2.80	2.53	0.65	2.68	2.47	0.71	2.63	2.44	0.73	2.56	2.40	0.77	2.44	2.34	0.83
22	30	3.09	2.50	0.60	2.98	2.44	0.66	2.86	2.39	0.71	2.81	2.37	0.74	2.74	2.33	0.77	2.62	2.27	0.83
24	32	3.21	2.43	0.61	3.09	2.38	0.66	2.98	2.33	0.72	2.93	2.31	0.74	2.86	2.27	0.77	2.74	2.22	0.83

Heating: 220 - 240V 50Hz

AFR	10.8
-----	------

Indoor Temperature		Outdoor Temperature [°C WB]											
EDB °C	°C	-15		-10		-5		0		6		10	
		TC	PI	TC	PI	TC	PI	TC	PI	TC	PI	TC	PI
15		1.35	0.48	1.63	0.51	1.90	0.53	2.18	0.69	2.94	0.73	3.20	0.76
20		1.27	0.50	1.54	0.52	1.82	0.54	2.09	0.72	2.84	0.75	3.10	0.77
22		1.23	0.50	1.51	0.53	1.78	0.55	2.06	0.72	2.80	0.75	3.06	0.78
24		1.20	0.50	1.48	0.53	1.75	0.56	2.02	0.73	2.76	0.76	3.02	0.79
25		1.18	0.51	1.46	0.53	1.73	0.56	2.01	0.73	2.74	0.77	3.00	0.79
27		1.15	0.51	1.43	0.54	1.70	0.56	1.97	0.73	2.70	0.77	2.96	0.80

SYMBOLS

- AFR : Air flow rate (m³/min.)
- BF : Bypass factor
- EWB : Entering wet bulb temp. (°C)
- EDB : Entering dry bulb temp. (°C)
- TC : Total capacity (kW)
- SHC : Sensible heat capacity (kW)
- PI : Power input (kW)

NOTES

1. shows nominal (rated) capacities and power input.
2. TC, PI and SHC must be calculated by interpolation using the figures in the above tables.
3. Capacities are based on the following conditions.
Corresponding refrigerant piping length: 7.5m
Level difference: 0.0m

3D121056B

4 Capacity tables

4 - 1 Cooling Capacity Tables

FTXC35D / RXC35D

Cooling: 220 - 240V 50Hz

AFR	11.04
BF	0.13

Indoor air temperature EWB	Indoor air temperature EDB	Outdoor Temperature [°C DB]																	
		20			25			30			32			35			40		
°C	°C	TC	SHC	PI	TC	SHC	PI	TC	SHC	PI	TC	SHC	PI	TC	SHC	PI	TC	SHC	PI
14	20	3.59	2.75	0.80	3.42	2.67	0.88	3.26	2.59	0.96	3.19	2.56	0.99	3.10	2.51	1.04	2.93	2.43	1.12
16	22	3.75	2.70	0.81	3.58	2.63	0.89	3.42	2.55	0.97	3.36	2.52	1.00	3.26	2.48	1.04	3.10	2.41	1.12
18	25	3.91	2.84	0.81	3.75	2.77	0.90	3.58	2.70	0.97	3.52	2.67	1.00	3.42	2.63	1.05	3.25	2.56	1.13
19	27	3.99	2.99	0.81	3.83	2.93	0.90	3.66	2.86	0.97	3.60	2.83	1.01	3.50	2.79	1.05	3.34	2.73	1.13
22	30	4.23	2.89	0.82	4.07	2.83	0.91	3.90	2.77	0.98	3.84	2.75	1.01	3.74	2.71	1.06	3.58	2.66	1.14
24	32	4.39	2.82	0.83	4.23	2.76	0.91	4.07	2.71	0.99	4.00	2.69	1.02	3.90	2.66	1.06	3.74	2.60	1.14

Heating: 220 - 240V 50Hz

AFR	11.04
-----	-------

Indoor air temperature EDB	Outdoor Temperature [°C DB]											
	-15		-10		-5		0		6		10	
°C	TC	PI	TC	PI	TC	PI	TC	PI	TC	PI	TC	PI
15	1.90	0.68	2.29	0.72	2.67	0.76	3.06	0.99	4.14	1.05	4.50	1.08
20	1.79	0.71	2.17	0.74	2.56	0.77	2.95	1.02	4.00	1.08	4.36	1.10
22	1.74	0.72	2.13	0.75	2.51	0.79	2.90	1.02	3.94	1.08	4.31	1.12
24	1.69	0.72	2.08	0.76	2.46	0.79	2.84	1.04	3.89	1.08	4.25	1.13
25	1.67	0.73	2.05	0.76	2.44	0.80	2.83	1.04	3.86	1.09	4.22	1.13
27	1.62	0.743	2.01	0.77	2.39	0.81	2.78	1.05	3.81	1.10	4.17	1.14

SYMBOLS

- AFR : Air flow rate (m³/min)
- BPF : Bypass factor
- EWB : Entering Wet Bulb (°C)
- EDB : Entering Dry Bulb (°C)
- TC : Total capacity (kW)
- SHC : Sensible heat capacity (kW)
- PI : Power input (kW)

NOTES

1. Shows nominal (rated) capacities and power input.
2. TC, SHC and PI must be calculated by interpolation using the figures in the above tables.
3. Capacities are based on the following conditions.
Corresponding refrigerant piping length : 7.5m
Level difference : 0.0m

3D142014

FTXC50DV1B / RXC50DV1B

Cooling: 220 - 240V 50Hz

AFR	12.46
BF	0.13

Indoor air temperature EWB	Indoor air temperature EDB	Outdoor Temperature [°C DB]																	
		20			25			30			32			35			40		
°C	°C	TC	SHC	PI	TC	SHC	PI	TC	SHC	PI	TC	SHC	PI	TC	SHC	PI	TC	SHC	PI
14	20	5.23	3.72	1.19	4.98	3.59	1.30	4.75	3.47	1.41	4.65	3.42	1.46	4.51	3.35	1.54	4.27	3.22	1.65
16	22	5.47	3.65	1.20	5.22	3.53	1.31	4.98	3.41	1.43	4.89	3.37	1.47	4.75	3.30	1.54	4.51	3.18	1.66
18	25	5.70	3.79	1.20	5.47	3.68	1.32	5.22	3.56	1.43	5.13	3.52	1.48	4.98	3.45	1.55	4.74	3.35	1.66
19	27	5.81	3.95	1.20	5.58	3.85	1.33	5.33	3.74	1.43	5.24	3.70	1.48	5.10	3.64	1.55	4.87	3.54	1.67
22	30	6.16	3.80	1.22	5.93	3.71	1.33	5.69	3.61	1.44	5.60	3.58	1.49	5.45	3.52	1.56	5.22	3.43	1.68
24	32	6.40	3.69	1.23	6.16	3.61	1.34	5.93	3.52	1.46	5.83	3.49	1.50	5.69	3.44	1.57	5.45	3.35	1.69

Heating: 220 - 240V 50Hz

AFR	12.46
-----	-------

Indoor air temperature EDB	Outdoor Temperature [°C DB]											
	-15		-10		-5		0		6		10	
°C	TC	PI	TC	PI	TC	PI	TC	PI	TC	PI	TC	PI
15	2.67	0.97	3.22	1.02	3.76	1.08	4.30	1.41	5.81	1.49	6.32	1.54
20	2.52	1.00	3.05	1.05	3.59	1.10	4.14	1.45	5.62	1.52	6.13	1.57
22	2.44	1.02	2.99	1.07	3.53	1.12	4.07	1.46	5.54	1.53	6.05	1.58
24	2.38	1.02	2.92	1.08	3.46	1.13	4.00	1.47	5.46	1.54	5.97	1.60
25	2.34	1.03	2.88	1.08	3.43	1.13	3.98	1.48	5.43	1.55	5.93	1.60
27	2.28	1.04	2.82	1.10	3.36	1.14	3.90	1.49	5.35	1.57	5.86	1.62

SYMBOLS

- AFR : Air flow rate (m³/min)
- BPF : Bypass factor
- EWB : Entering Wet Bulb (°C)
- EDB : Entering Dry Bulb (°C)
- TC : Total capacity (kW)
- SHC : Sensible heat capacity (kW)
- PI : Power input (kW)

NOTES

1. Shows nominal (rated) capacities and power input.
2. TC, SHC and PI must be calculated by interpolation using the figures in the above tables.
3. Capacities are based on the following conditions.
Corresponding refrigerant piping length : 7.5m
Level difference : 0.0m

3D142020

4 Capacity tables

4 - 1 Cooling Capacity Tables

4

FTXC60D / RXC60D

Cooling: 220 - 240V 50Hz

AFR	20.4
BF	0.13

Indoor air temperature		Outdoor Temperature [°C DB]																	
EWB °C	EDB °C	20			25			30			32			35			40		
		TC	SHC	PI	TC	SHC	PI	TC	SHC	PI	TC	SHC	PI	TC	SHC	PI	TC	SHC	PI
14	20	6.38	4.94	1.45	6.09	4.78	1.59	5.80	4.63	1.72	5.68	4.57	1.78	5.51	4.47	1.87	5.22	4.31	2.01
16	22	6.68	4.86	1.46	6.38	4.70	1.59	6.08	4.56	1.74	5.98	4.51	1.80	5.80	4.41	1.87	5.51	4.28	2.02
18	25	6.96	5.07	1.47	6.68	4.94	1.61	6.38	4.79	1.74	6.27	4.74	1.80	6.08	4.65	1.89	5.79	4.53	2.03
19	27	7.10	5.33	1.47	6.81	5.19	1.61	6.52	5.07	1.74	6.40	5.01	1.80	6.23	4.93	1.89	5.94	4.81	2.04
22	30	7.53	5.13	1.48	7.24	5.01	1.62	6.95	4.90	1.76	6.83	4.86	1.82	6.66	4.78	1.91	6.38	4.67	2.05
24	32	7.82	4.99	1.49	7.53	4.89	1.63	7.24	4.78	1.78	7.12	4.74	1.83	6.95	4.67	1.91	6.66	4.56	2.06

Heating: 220 - 240V 50Hz

AFR	20.4
-----	------

Indoor air temperature		Outdoor Temperature [°C DB]											
EDB °C	°C	-15		-10		-5		0		6		10	
		TC	PI	TC	PI	TC	PI	TC	PI	TC	PI	TC	PI
15	20	3.04	1.08	3.66	1.13	4.28	1.19	4.90	1.56	6.62	1.65	7.20	1.70
20	20	2.87	1.11	3.47	1.16	4.09	1.22	4.71	1.60	6.40	1.68	6.98	1.73
22	28	2.78	1.13	3.40	1.18	4.02	1.23	4.63	1.61	6.31	1.69	6.89	1.75
24	24	2.71	1.13	3.33	1.19	3.94	1.25	4.55	1.63	6.22	1.70	6.80	1.77
25	25	2.67	1.14	3.28	1.19	3.91	1.25	4.53	1.64	6.18	1.71	6.75	1.77
27	26	2.60	1.15	3.21	1.21	3.82	1.27	4.44	1.65	6.09	1.73	6.67	1.79

SYMBOLS

- AFR : Air flow rate (m³/min)
- BPF : Bypass factor
- EWB : Entering Wet Bulb (°C)
- EDB : Entering Dry Bulb (°C)
- TC : Total capacity (kW)
- SHC : Sensible heat capacity (kW)
- PI : Power input (kW)

NOTES

1. Shows nominal (rated) capacities and power input.
2. TC, SHC and PI must be calculated by interpolation using the figures in the above tables.
3. Capacities are based on the following conditions.
Corresponding refrigerant piping length : 7.5m
Level difference : 0.0m

3D121073B

FTXC71D / RXC71D

Cooling: 220 - 240V 50Hz

AFR	20.4
BF	0.13

Indoor air temperature		Outdoor Temperature [°C DB]																	
EWB °C	EDB °C	20			25			30			32			35			40		
		TC	SHC	PI	TC	SHC	PI	TC	SHC	PI	TC	SHC	PI	TC	SHC	PI	TC	SHC	PI
14	20	7.28	5.05	1.82	6.94	4.89	2.00	6.61	4.73	2.17	6.48	4.67	2.24	6.28	4.57	2.36	5.94	4.41	2.53
16	22	7.61	4.97	1.84	7.27	4.80	2.01	6.93	4.66	2.19	6.81	4.61	2.26	6.61	4.51	2.36	6.28	4.37	2.54
18	25	7.93	5.18	1.85	7.61	5.05	2.03	7.27	4.90	2.20	7.14	4.84	2.27	6.93	4.76	2.38	6.60	4.63	2.55
19	27	8.09	5.45	1.85	7.76	5.31	2.03	7.43	5.18	2.20	7.30	5.12	2.27	7.10	5.04	2.38	6.77	4.92	2.57
22	30	8.58	5.25	1.87	8.26	5.12	2.05	7.92	5.01	2.22	7.79	4.97	2.29	7.59	4.89	2.40	7.27	4.77	2.58
24	32	8.91	5.10	1.88	8.58	5.00	2.05	8.26	4.89	2.24	8.12	4.85	2.31	7.92	4.77	2.41	7.59	4.66	2.59

Heating: 220 - 240V 50Hz

AFR	20.4
-----	------

Indoor air temperature		Outdoor Temperature [°C DB]											
EDB °C	°C	-15		-10		-5		0		6		10	
		TC	PI	TC	PI	TC	PI	TC	PI	TC	PI	TC	PI
15	20	3.80	1.57	4.58	1.66	5.35	1.75	6.13	2.28	8.27	2.41	9.00	2.49
20	20	3.58	1.62	4.34	1.70	5.12	1.78	5.89	2.35	8.00	2.46	8.73	2.54
22	28	3.48	1.65	4.25	1.73	5.02	1.81	5.79	2.36	7.88	2.47	8.62	2.56
24	24	3.38	1.65	4.16	1.75	4.92	1.83	5.69	2.38	7.78	2.49	8.51	2.59
25	25	3.34	1.67	4.10	1.75	4.88	1.83	5.66	2.40	7.73	2.51	8.44	2.60
27	26	3.25	1.68	4.02	1.78	4.78	1.85	5.55	2.41	7.61	2.54	8.34	2.62

SYMBOLS

- AFR : Air flow rate (m³/min)
- BPF : Bypass factor
- EWB : Entering Wet Bulb (°C)
- EDB : Entering Dry Bulb (°C)
- TC : Total capacity (kW)
- SHC : Sensible heat capacity (kW)
- PI : Power input (kW)

NOTES

1. Shows nominal (rated) capacities and power input.
2. TC, SHC and PI must be calculated by interpolation using the figures in the above tables.
3. Capacities are based on the following conditions.
Corresponding refrigerant piping length : 7.5m
Level difference : 0.0m

3D121397B

5 Dimensional drawings

5 - 1 Dimensional Drawings

RXC20-35D
ARXC20-35D

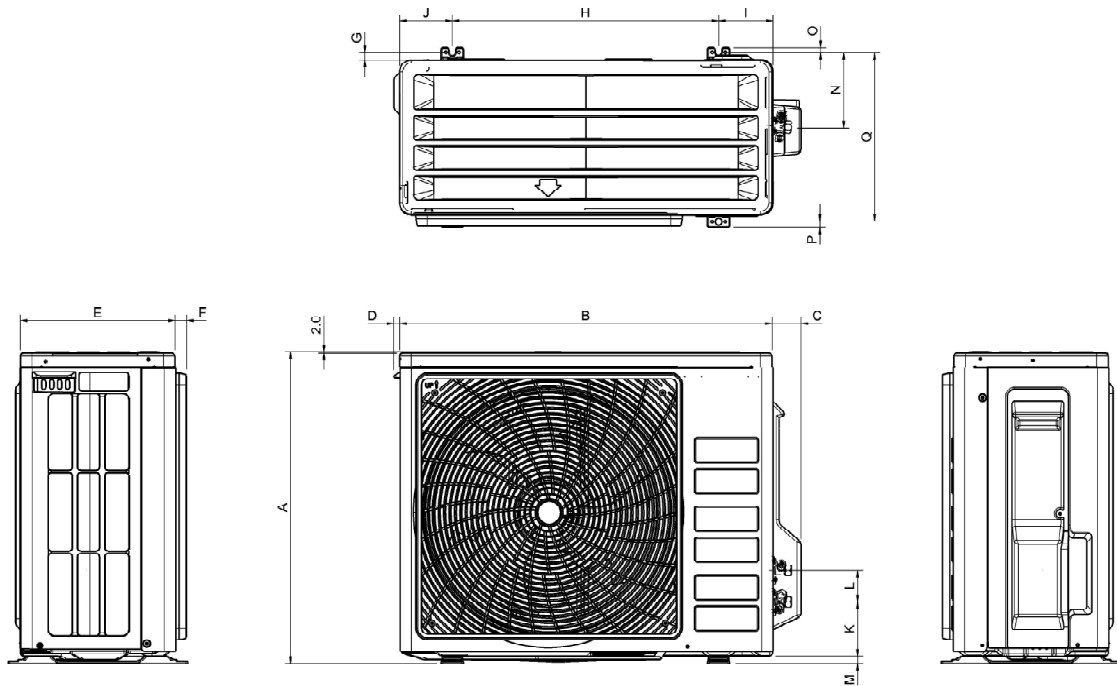

MODEL	A	B	C	D	E	F	G	H	I	J	K	L	M	N	O	P	Q
3SLY 10/15 FR	550	658	51	11	273	20	11	170	96	93	94	60	11	133	8	10	299

R70014157623

ARXC50-60D
RXC50-60D

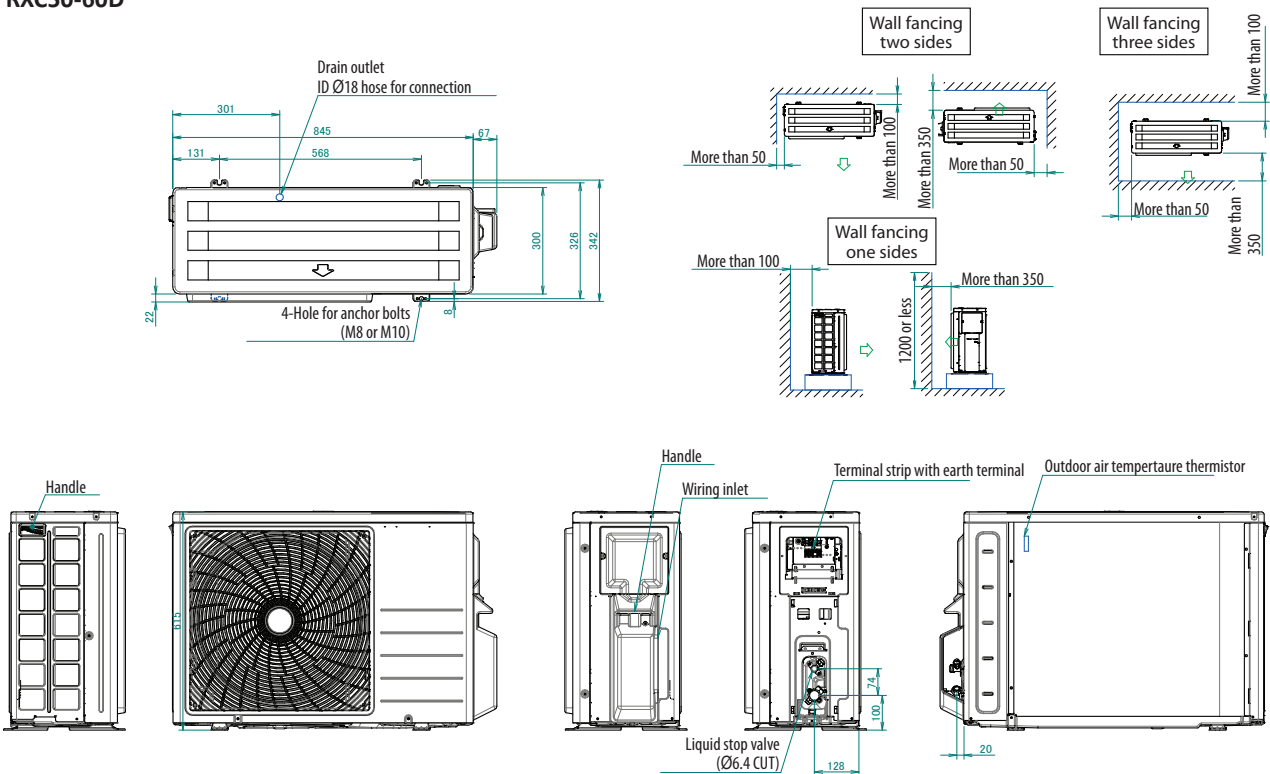

3D117130J

5 Dimensional drawings

5 - 1 Dimensional Drawings

5

ARXC50-60D
RXC50-60D

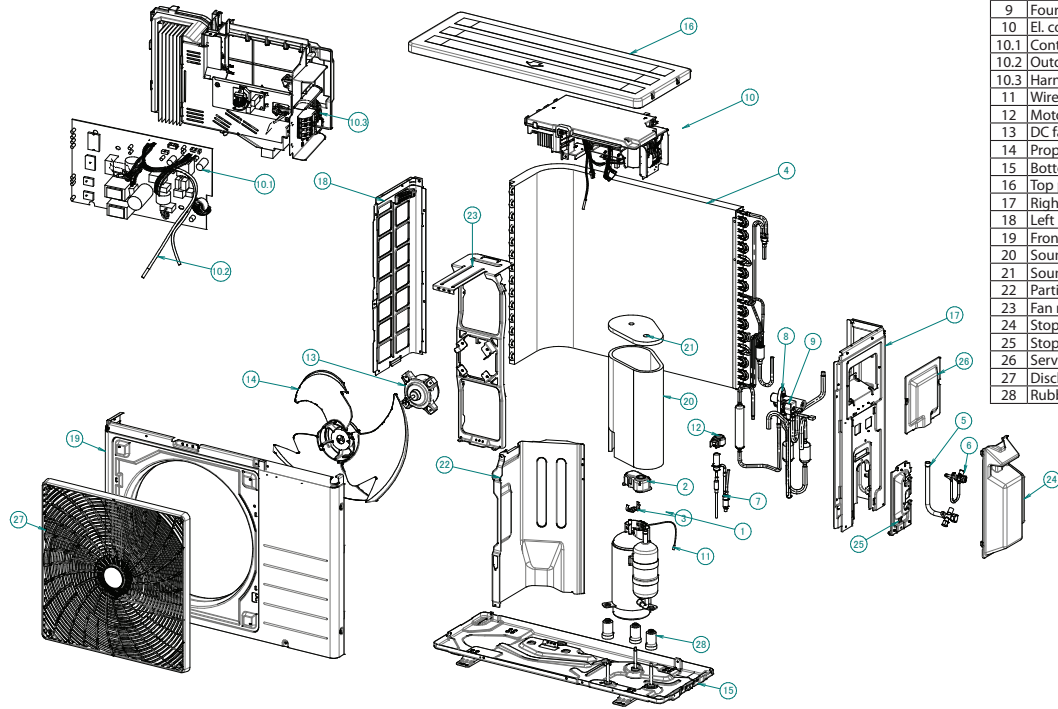

No	Description
1	Compressor
2	Terminal cover
3	Overload relay mounting plate
4	Heat exchanger assy
5	Gas stop valve assy
6	Liquid stop valve assy
7	Motor operated valve assy
8	Four way valve assy
9	Four way valve coil assy
10	El. compo. assy
10.1	Control module
10.2	Outdoor thermistor
10.3	Harness wire
11	Wire harness (compressor)
12	Motor operated valve coil
13	DC fan motor
14	Propeller fan assy
15	Bottom frame assy
16	Top plate assy
17	Right side plate
18	Left side plate
19	Front plate assy
20	Sound insulation (sleeve)
21	Sound insulation (top)
22	Partition plate
23	Fan motor stand assy
24	Stop valve cover
25	Stop valve mounting plate
26	Service cover assy
27	Disch. grille
28	Rubber grommet

3D120767A

ARXC71D
RXC71D

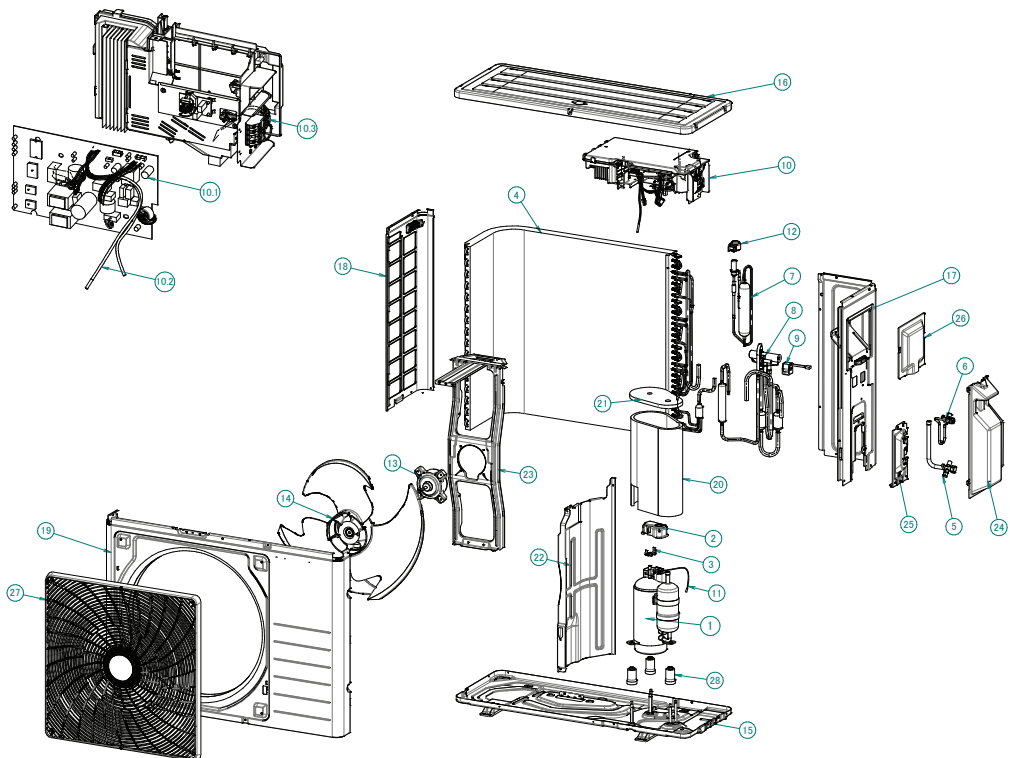

No	Description
1	Compressor
2	Terminal cover
3	Overload relay mounting plate
4	Heat exchanger assy
5	Gas stop valve assy
6	Liquid stop valve assy
7	Motor operated valve assy
8	Four way valve assy
9	Four way valve coil assy
10	El. compo. assy
10.1	Control module
10.2	Outdoor thermistor
10.3	Harness wire
11	Wire harness (compressor)
12	Motor operated valve coil
13	DC fan motor
14	Propeller fan assy
15	Bottom frame assy
16	Top plate assy
17	Right side plate
18	Left side plate
19	Front plate assy
20	Sound insulation (sleeve)
21	Sound insulation (top)
22	Partition plate
23	Fan motor stand assy
24	Stop valve cover
25	Stop valve mounting plate
26	Service cover assy
27	Disch. grille
28	Rubber grommet

3D120856A

5 Dimensional drawings

5 - 1 Dimensional Drawings

ARXC71D
RXC71D

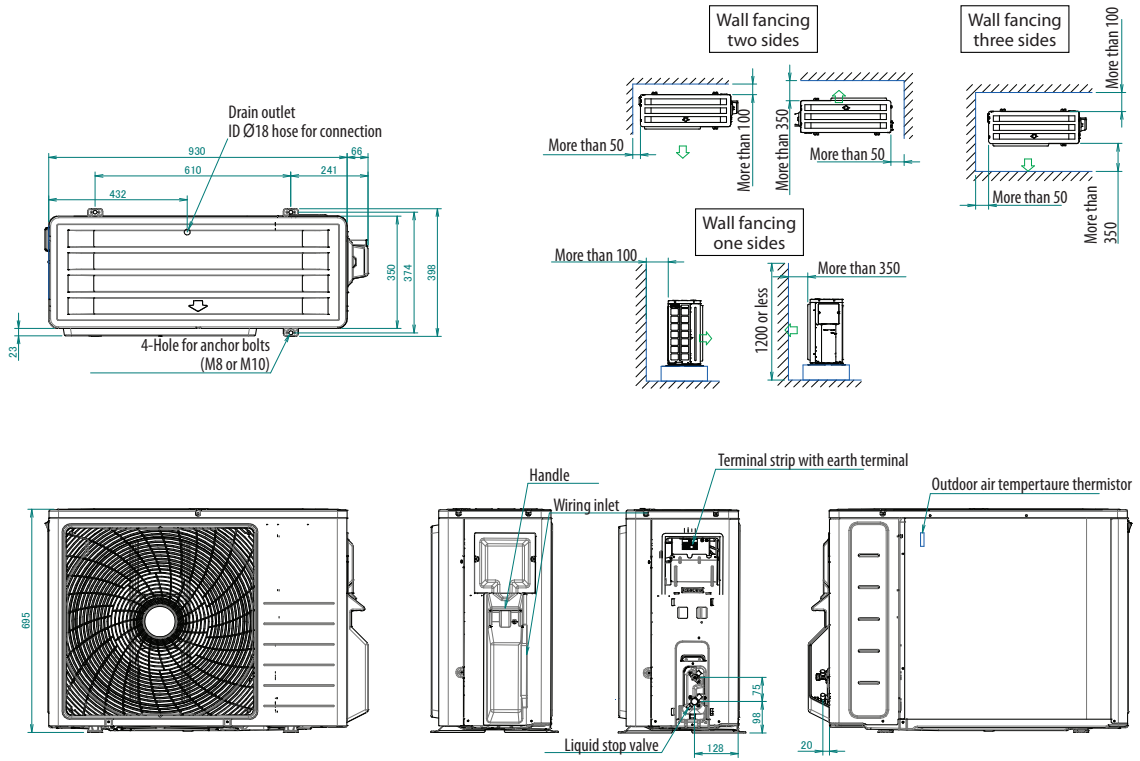

3D121403D

6 Piping diagrams

6-1 Piping Diagrams

6

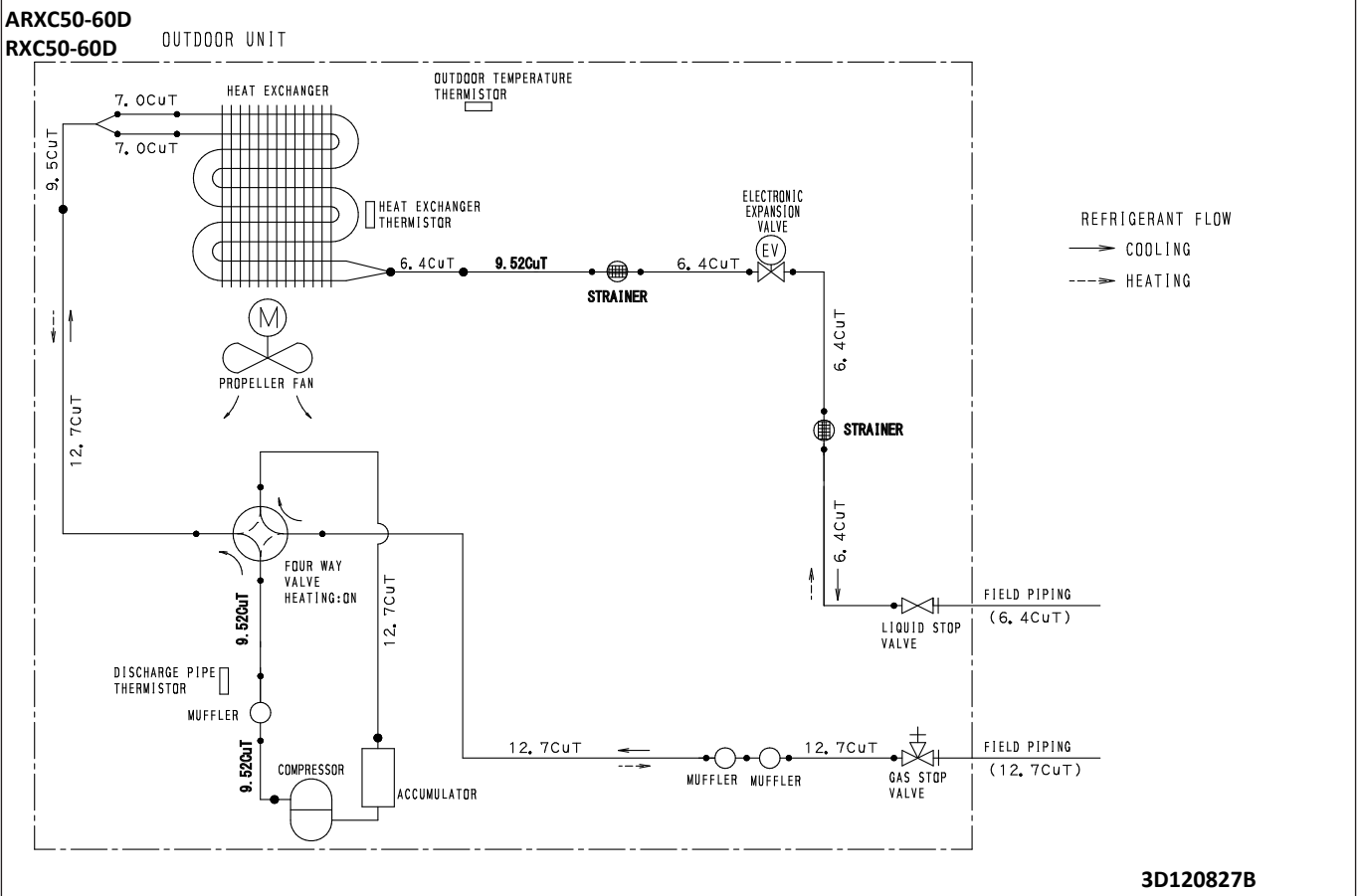
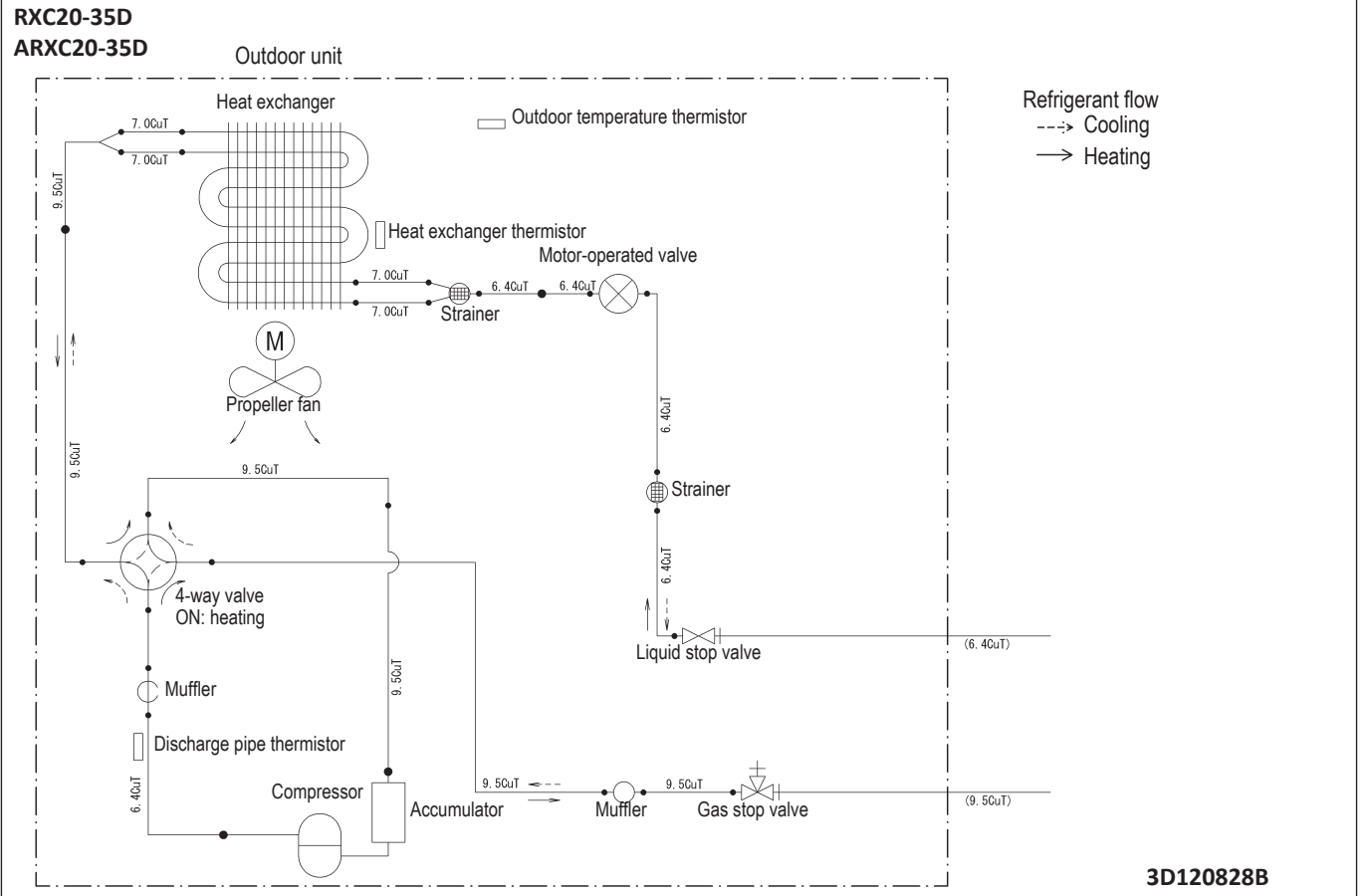

6 Piping diagrams

6 - 1 Piping Diagrams

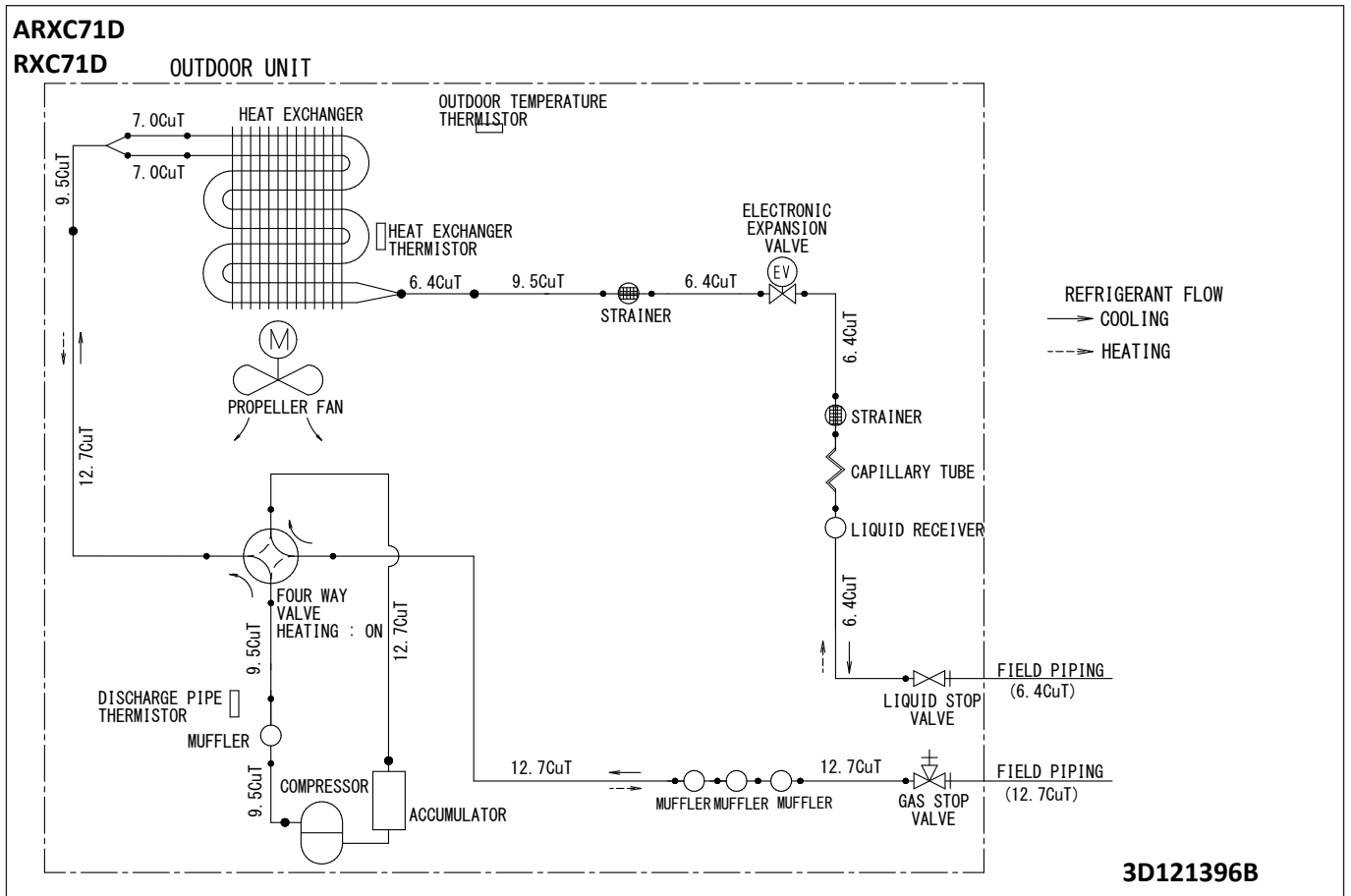

7 Wiring diagrams

7 - 1 Wiring Diagrams - Three Phase

7

ARXC20-35D
RXC20-35D

NOTATION

- MF : Fan motor
- MC : Compressor motor
- OLP : Overload protector
- Z1C, Z2C, Z3C : Ferrite core
- ID : Indoor
- EXV : Electronic expansion valve
- 4WV : Four way valve
- : Field supply wiring

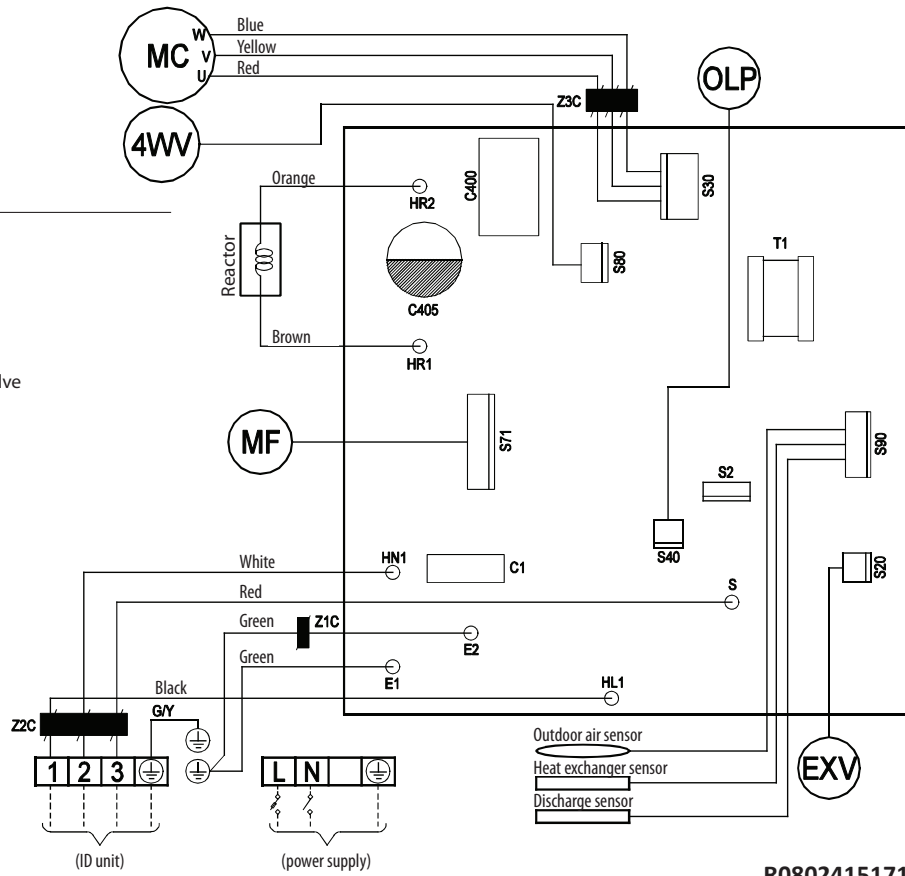

R08024151718

ARXC50-71D
RXC50-71D

NOTATION

- MC : Compressor motor
- MF : Fan motor
- OLP : Overload protector
- TB : Terminal block
- EXV : Electronic expansion valve coil
- X11A, X12A : Connector
- Z1C, Z2C, Z3C : Ferrite core
- 4WV : Four way valve
- : Field supply wiring

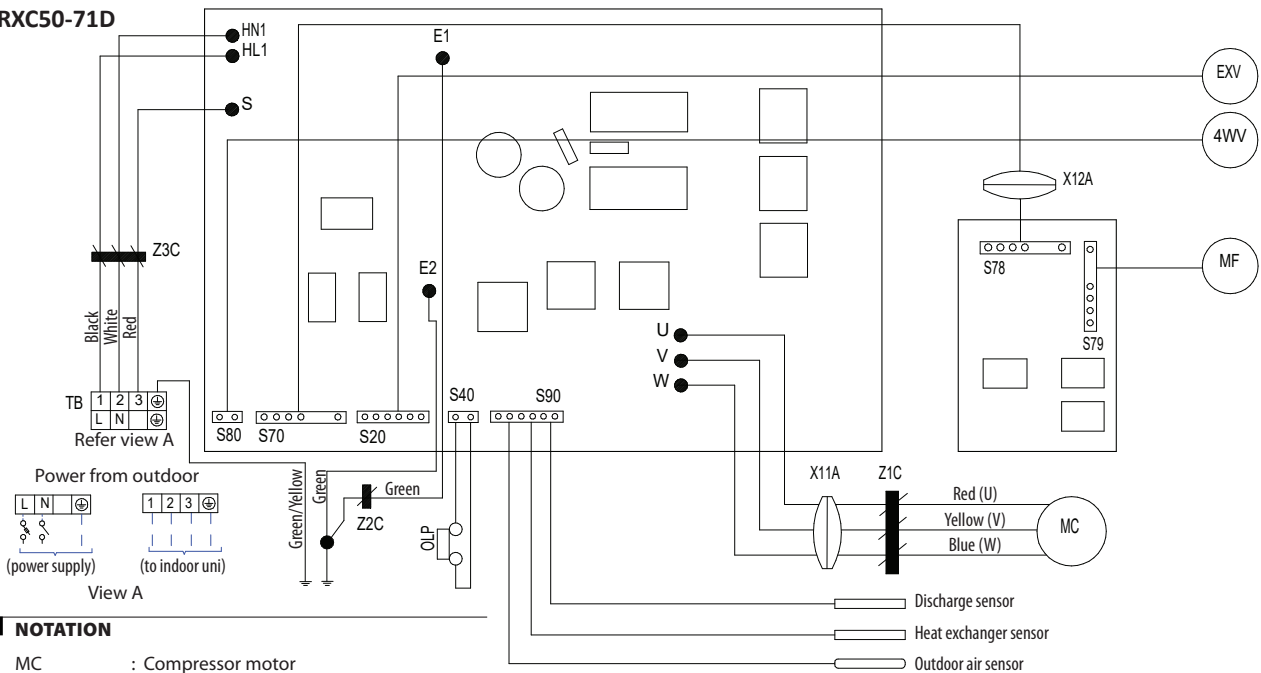

3P552447B

8 Sound data

8 - 1 Sound Pressure Spectrum

ARXC20-25D RXC20-25D

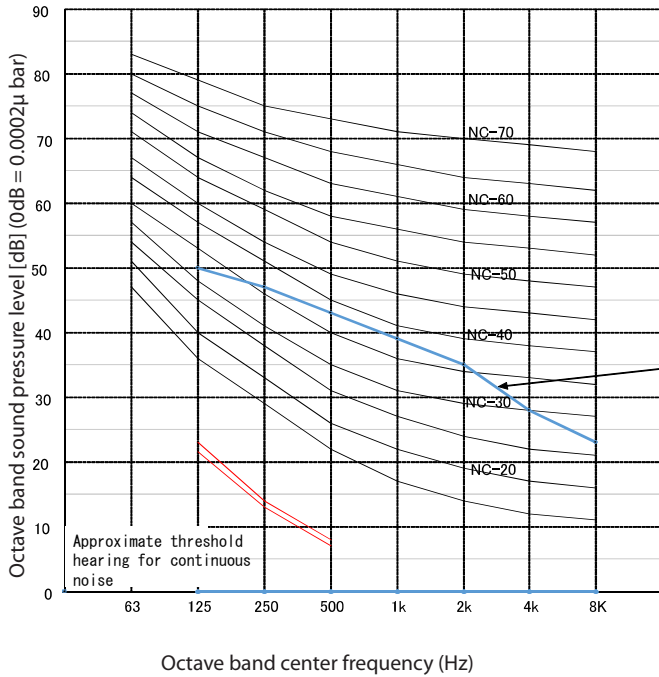

NOTES

1. Measuring place
Anechoic chamber
Operation noise differs with operation and ambient conditions.
2. Operating conditions
Power source: 220-240V 50Hz
3. Location of microphone.

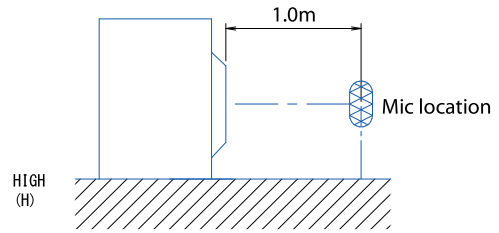

Fan speed	Testing Data Input							Overall (dBA)	Noise criteria
	125	250	500	1k	2k	4k	8k		
H	50	47	43	39	35	28	23	45	38

3D141724

ARXC35D RXC35D

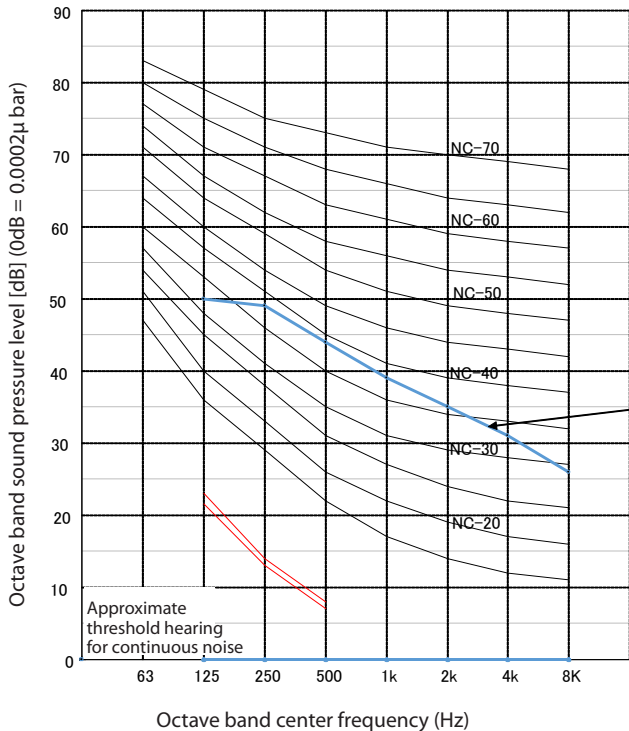

NOTES

1. Measuring place
Anechoic chamber
Operation noise differs with operation and ambient conditions.
2. Operating conditions
Power source: 220-240V 50Hz
3. Location of microphone.

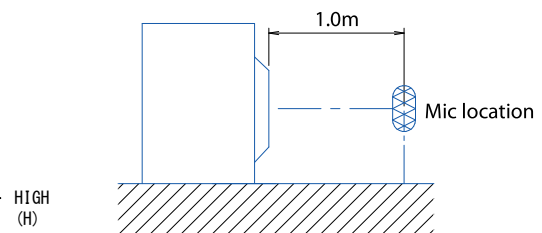

Fan speed	Testing Data Input							Overall (dBA)	Noise criteria
	125	250	500	1k	2k	4k	8k		
H	50	49	44	39	35	31	26	46	39

3D141726

8 Sound data

8 - 1 Sound Pressure Spectrum

8

ARXC50D
RXC50D

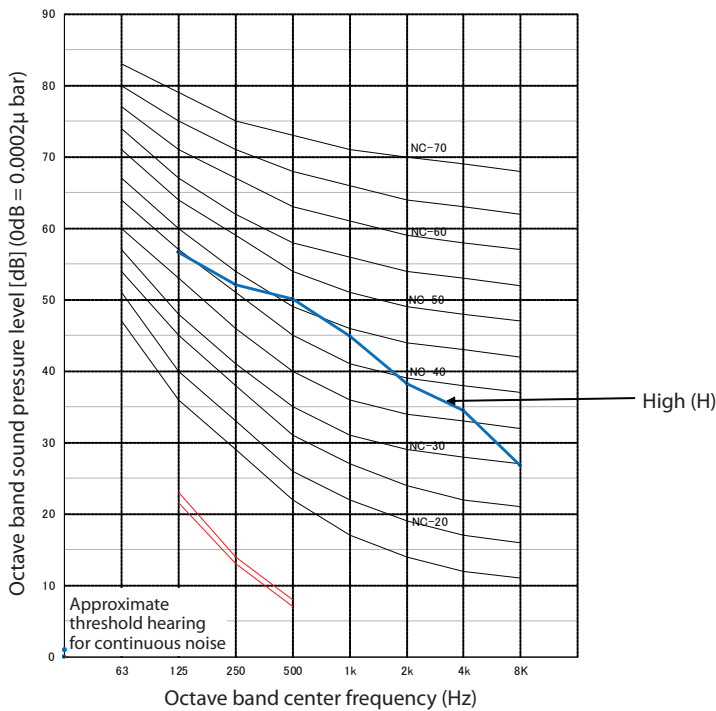

NOTES

1. Measuring place
Anechoic chamber
Operation noise differs with operation and ambient conditions.
2. Operating conditions
Power source: 220-240V 50Hz
3. Location of microphone.

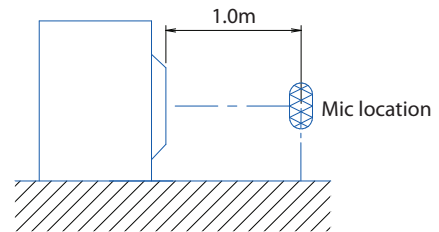

Fan speed	Testing Data Input							Overall (dBA)	Noise criteria
	125	250	500	1k	2k	4k	8k		
H	57	52	50	45	38	34	27	51	46

3D118144C

ARXC60D
RXC60D

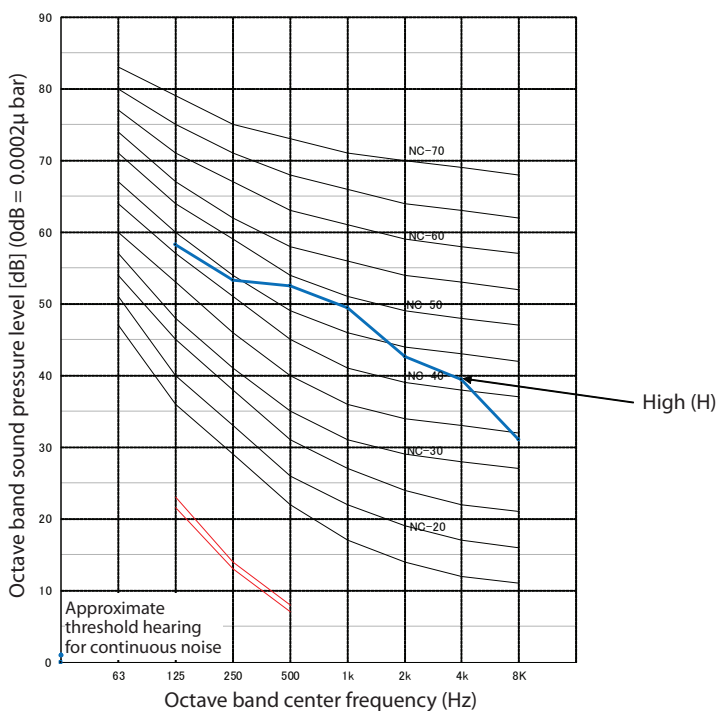

NOTES

1. Measuring place
Anechoic chamber
Operation noise differs with operation and ambient conditions.
2. Operating conditions
Power source: 220-240V 50Hz
3. Location of microphone.

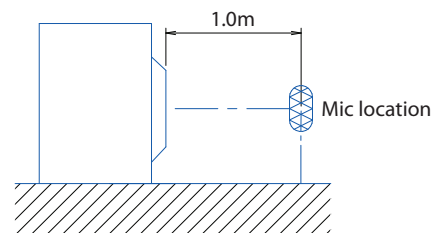

Fan speed	Testing Data Input							Overall (dBA)	Noise criteria
	125	250	500	1k	2k	4k	8k		
H	58	53	52	49	43	39	31	54	49

3D121139B

8 Sound data

8 - 1 Sound Pressure Spectrum

ARXC71D
RXC71D

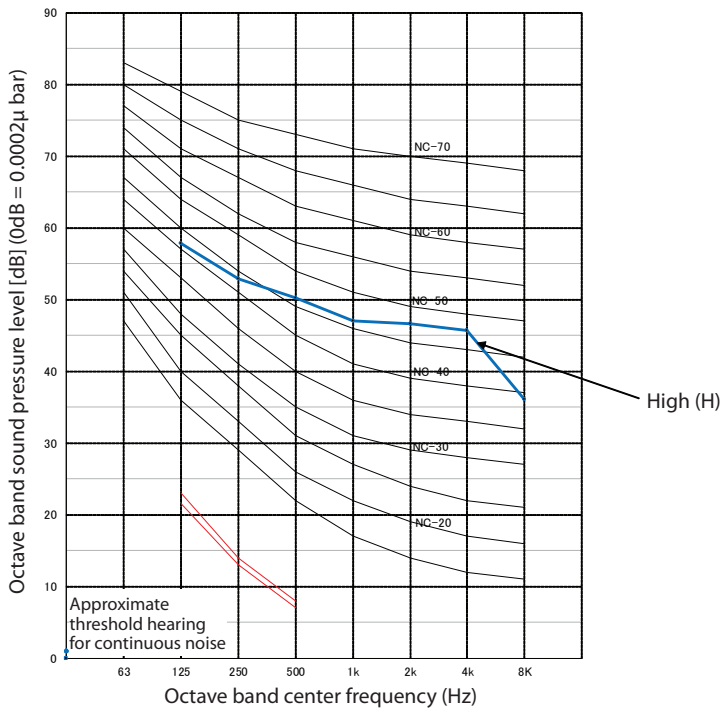

NOTES

1. Measuring place
Anechoic chamber
Operation noise differs with operation and ambient conditions.
2. Operating conditions
Power source: 220-240V 50Hz
3. Location of microphone.

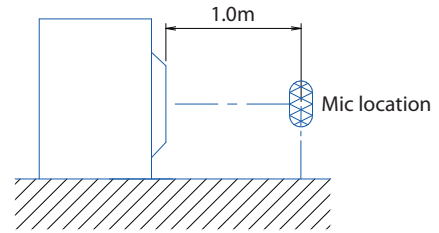

Fan speed	Testing Data Input							Overall (dBA)	Noise criteria
	125	250	500	1k	2k	4k	8k		
H	58	53	50	47	47	46	36	54	48

3D121445B

9 Operation range

9 - 1 Operation Range

9

RXC20-35D
ARXC20-35D

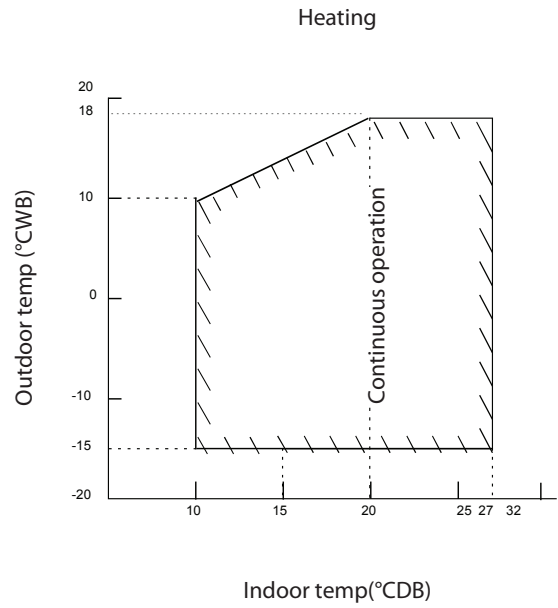
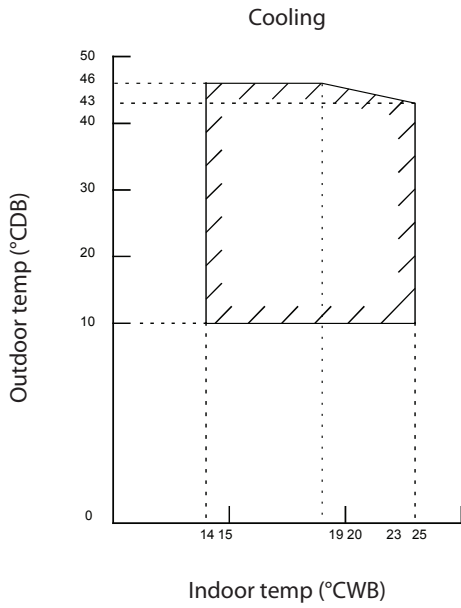

DB: Dry bulb WB: Wet bulb

3P621327-2E / 3P622386-2E

RXC50-71D
ARXC50-71D

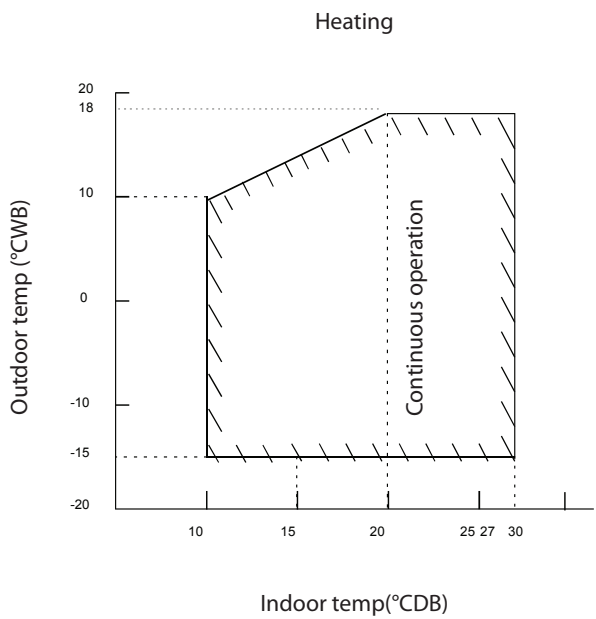
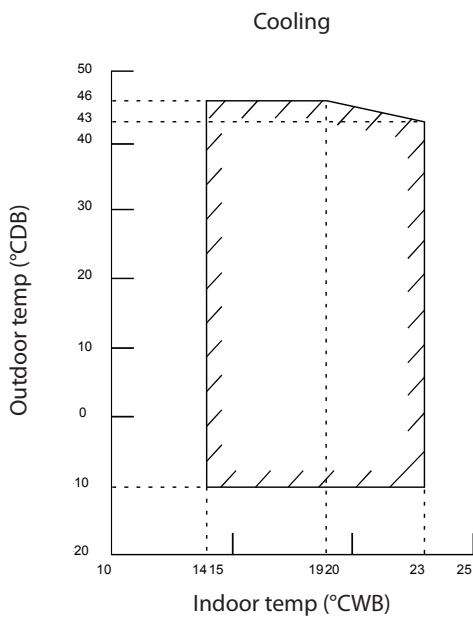

DB: Dry bulb WB: Wet bulb

3P621327-2E / 3P622386-2E

Daikin Europe N.V. Naamloze Vennootschap · Zandvoordestraat 300 · 8400 Oostende · Belgium · www.daikin.eu · BE 0412 120 336 · RPR Oostende (Responsible Editor)

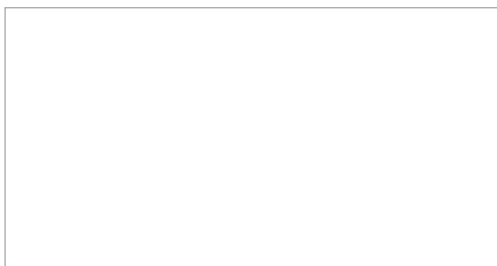

Daikin Europe N.V. participates in the ECP programmes for Fan Coil Units and Variable Refrigerant Flow systems. Daikin Applied Europe S.p.A. participates in the ECP programmes for Liquid Chilling Packages and Hydronic Heat Pumps. Check ongoing validity of certificate: www.eurovent-certification.com

EEEN22

11/2022



The present leaflet is drawn up by way of information only and does not constitute an offer binding upon Daikin Europe N.V. Daikin Europe N.V. has compiled the content of this leaflet to the best of its knowledge. No express or implied warranty is given for the completeness, accuracy, reliability or fitness for particular purpose of its content and the products and services presented therein. Specifications are subject to change without prior notice. Daikin Europe N.V. explicitly rejects any liability for any direct or indirect damage, in the broadest sense, arising from or related to the use and/or interpretation of this leaflet. All content is copyrighted by Daikin Europe N.V.